

# SC

---

## Service Connector

**SC Message Protocol V1.3**

**SC\_0\_SCMP-V1.3\_E (Version V2.42)**

---

**This document describes the SC Message Protocol V1.3 (SCMP).**

**Copyright © 2010 STABILIT Informatik AG, Switzerland**

**Licensed under the Apache License, Version 2.0 (the "License"); you may not use this file except in compliance with the License. You may obtain a copy of the License at**

**<http://www.apache.org/licenses/LICENSE-2.0>**

**Unless required by applicable law or agreed to in writing, software distributed under the License is distributed on an "AS IS" BASIS, WITHOUT WARRANTIES OR CONDITIONS OF ANY KIND, either express or implied. See the License for the specific language governing permissions and limitations under the License.**

All other logos, product names are trademarks of their respective owners.

This Document has been created with Microsoft Word 2003 (11) with template file C:\STABILIT\STANDARD\TEMPLATES\S\_REP\_E.DOT and printed at 08 October 2012 11:14.

## Identification

|                            |  |
|----------------------------|--|
| Project:                   | SC   |
| Title:                     | Service Connector  |
| Subtitle:                  | SC Message Protocol V1.3   |
| Version:                   | V2.42  |
| Reference:                 | SC_0_SCMP-V1.3_E   |
| Classification:            | Public   |
| Keywords:                  | Concepts, Communication, Protocol                                |
| Comment:                   | This document describes the SC Message Protocol V1.3 (SCMP).     |
| Author(s):                 | STABILIT Informatik AG<br>Jan Trnka, Daniel Schmutz, Joël Traber |
| Approval<br>(Reviewed by): | Signature ..... Jan Trnka  |
| Audience:                  | Project team, Review team  |
| Distribution:              | Public   |
| Filename                   | c:\stabilit\projects\leurex\sc\documents\sc_0_scmp_e-v2.42.docx  |

## Revision History

| Date       | Version | Author    | Description  |
|------------|---------|-----------|--|
| 14.06.2009 | D1.0    | Jan Trnka | Initial draft  |
| 09.08.2009 | D1.1    | Jan Trnka | Separate specification and architecture documents. Fill information from Daniel into this document.  |
| ...        | ...     | Jan Trnka | Many changes in between not tracked  |
| 24.2.2010  | V2.0    | Jan Trnka | Proposal for C-API   |
| 3.3.2010   | V2.1    | Jan Trnka | Remove SC architecture from this document  |
| 11.4.2010  | V2.2    | Jan Trnka | Prepare for review   |
| 14.4.2010  | V2.3    | Jan Trnka | Put API into its own document  |
| 2.6.2010   | V2.4    | Jan Trnka | Multi-Session Server changed, ATTACH instead of CONNECT  |
| 15.6.2010  | V2.5    | Jan Trnka | Corrections after SIX workshop and review  |
| 30.6.2010  | V2.6    | Jan Trnka | Cleanup confusion detected by R. Frey<br>Improve keep-alive description<br>Attr. <i>authSessionId</i> introduced<br>Attr. <i>noDataInterval</i> introduced<br>Headline format changed<br>Chapter "Subscription monitoring" added<br>Matrix reviewed<br>Last header attr. Also terminated with <LF><br>Definition of file services and http proxy.  |
| 2.7.2010   | V2.7    | Jan Trnka | Noi attribute changed, omi updated.  |
| 21.7.2010  | V2.8    | Jan Trnka | CLN_CREATE_SESSION,SRV_CREATE_SESSION,CLN_SUBSCRIBE,SRV_SUBSCRIBE,CLN_CHANGE_SUBSCRIPTION,SRV_CHANGE_SUBSCRIPTION may optionally have a body.<br>SRV_ABORT_SESSION change  |
| 15.8.2010  | V2.9    | Jan Trnka | "=" or <LF> are not allowed within attribute names and/or values.<br>Unknown header attributes will be forwarded.<br>Large message are not possible for CLN_CREATE_SESSION or CLN_SUBSCRIBE.<br>Mid is never set in case of an error.<br>Publishing of large messages possible from one server only.<br>MANAGE message described.<br>Attribute default values introduced.<br>Chapter <i>Restrictions</i> moved to design document.<br>Restructuring of the document.<br>echoTimeout superseded by operationTimeout |

|            |       |           |  |
|------------|-------|-----------|--|
| 23.8.2010  | V2.10 | Jan Trnka | Restrictions added again<br>State and relationship diagrams<br>serviceName limited to 32 chars.<br>DATA message renamed to EXECUTE   |
| 6.9.2010   | V2.11 | Jan Trnka | Minor document restructuring<br>Unknown header attributes will ignored, NOT be forwarded.<br>Session monitoring changed. CLN_ECHO replaced by ECHO,<br>SRV_ECHO eliminated, ECHO response sent by SC.<br>State fallback on error added<br>Possible error codes added   |
| 19.9.2010  | V2.12 | Jan Trnka | operationTimeout (oti) is now in milliseconds  |
| 22.9.2010  | V2.13 | Jan Trnka | REGISTER_SERVICE renamed to REGISTER_SERVER and<br>analogous DEREGISTER_SERVICE to DEREGISTER_SERVER,<br>MTY remains the same!   |
| 13.10.2010 | V2.14 | Jan Trnka | authenticatedSession (asi) removed<br>cascadedMask (cma) introduced<br>Errors in publishing service description and messages corrected.<br>ipAddressList (ipl) required for INSPECT and MANAGE<br>operationTimeout (oti) is in all client requests (sometimes optional)<br>CacheId is unique per service   |
| 20.10.2010 | V2.15 | Jan Trnka | Exceeded oti in SRV_EXECUTE will cause<br>SRV_ABORT_SESSION.   |
| 25.10.2010 | V2.16 | Jan Trnka | Session handling in file services<br>ipAddressList (ipl) has port numbers  |
| 02.11.2010 | V2.17 | Jan Trnka | ced sent only by server. Caching changed.<br>Single session server is simplification of multi-session server.<br>Optional sin (sessionInformation) in DELETE_SESSION and<br>UNSUBSCRIBE<br>Changes of V2.15 reverted. Exceeded oti in SRV_EXECUTE will<br>NOT cause SRV_ABORT_SESSION.<br>MessageID (mid) replaced by messageSequenceNumber (msn)<br>OriginalMessageID (omi) replaced by<br>originalMessageSequenceNumber (oms)<br>PAC header key introduced |
| 29.11.2010 | V2.18 | Jan Trnka | Message body in CREATE_SESSION, SUBSCRIBE and<br>CHANGE_SUBSCRIPTION reply.<br>Invalid cache handling<br>Port number removed from ipl (ipAddressList)<br>csi (cascaded session id) introduced<br>description of msi – messageSequenceNr changed and enhanced.<br>Oms – originalMessageSeqNr removed<br>mxc is mandatory in REGISTER_SERVER<br>mxc validation changed<br>port number must be > 1  |
| 9.12.2010  | V2.19 | Jan Trnka | set/sec is also possible in server response  |
| 10.12.2010 | V2.20 | Jan Trnka | rej – reject flag can be also in SRV_SUBSCRIBE,<br>SRV_CHANGE_SUBSCRIPTION<br>aeclaet are possible whenever server responds with message body<br>set/sec in server response does not make sense for regular server.  |
| 17.12.2010 | V2.21 | Jan Trnka | oti used only for pass-through or cascaded messages.<br>CHECK_REGISTRATION message introduced<br>ams actualMask attribute introduced for<br>SRV_CHANGE_SUBSCRIPTION<br>crq, brq, brs, srq, srs are not useful and have been deleted.<br>Terminology “proxy” is confusing. Changed to “cascading”.  |
| 28.12.2010 | V2.22 | Jan Trnka | Attributes longer then defined length will be truncated.<br>Reference to compression algorithm added.  |
| 15.1.2011  | V2.23 | Jan Trnka | aec special value -9999 introduced.<br>Eci minimum value is 10 seconds<br>nio minimum value is 10 seconds<br>urp introduced (optional in REGISTER_SERVER)<br>cid passed to server in SRV_EXECUTE request<br>Message caching description improved.<br>Error description finalized   |
| 17.1.2011  | V2.24 | Jan Trnka | Improve description of caching.<br>Finalize for review.  |
| 18.1.2011  | V2.25 | Jan Trnka | clear cache command added to manage message<br>description of oti enhanced   |
| 26.1.2011  | V2.26 | Jan Trnka | nam is mandatory where it was informational<br>cascading subscription schema changed<br>Document declassified  |
| 11.2.2011  | V2.27 | Jan Trnka | sin is optionally available also in reply to CREATE_SESSION,<br>SUBSCRIBE and CHANGE_SUBSCRIPTION  |

|            |       |             |  |
|------------|-------|-------------|--|
| 16.2.2011  | V2.28 | Jan Trnka   | CSC_SUBSCRIBE, CSC_CHANGE_SUBSCRIPTION, SCS_UNSUBSCRIBE introduced for cascading.<br><i>Cpn</i> = cachePart number introduced.   |
| 25.2.2011  | V2.29 | Jan Trnka   | CSC_ABORT_SESSION introduced<br>Chapter 3.2 SRV_ABORT_SESSION sent when subscription is aborted.   |
| 28.2.2011  | V2.30 | Jan Trnka   | SRV_ABORT_SUBSCRIPTION introduced,<br>SRV_ABORT_SESSION is used only for session services<br>Inspect, manage message body has new syntax.<br>SCMP version number set to 1.1  |
| 4.3.2011   | V2.31 | Jan Trnka   | “http proxy service” renamed to “http redirection service”, because “proxy” has slightly different behavior.<br>New messages between cascaded SC introduced:<br>SCS_CREATE_SESSION, SCS_DELETE_SESSION,<br>SCS_EXECUTE |
| 15.4.2011  | V2.32 | Joël Traber | Added format of function <i>scVersion</i> , <i>serviceConfiguration</i> to <i>inspectCommand</i> .   |
| 23.5.2011  | V2.33 | Jan Trnka   | <i>eci</i> logic improved in order to ensure correct cleanup of dead requests<br>new <i>set/sec</i> for parallel request.  |
| 6.6.2011   | V2.34 | Jan Trnka   | ECHO message sent even if EXECUTE is in progress.  |
| 15.6.2011  | V2.35 | Jan Trnka   | New Error message HV_WRONG_KEEPALIVE_TIMEOUT   |
| 27.6.2011  | V2.36 | Jan Trnka   | <i>immediateConnect</i> = true controls static pool  |
| 6.8.2011   | V2.37 | Jan Trnka   | New error code HV_WRONG_RECEIVE_PUBLICATION_TIMEOUT<br>Server connection monitoring description added  |
| 18.7.2011  | V2.38 | Jan Trnka   | Protocol change, add <i>checkRegistrationInterval</i> to REGISTER_SERVER, server monitoring changed and finalized.   |
| 12.8.2011  | V2.39 | Jan Trnka   | Caching logic changed after code redesign and rewrite.   |
| 22.8.2012  | V2.40 | Joël Traber | Protocol enhancement to Version 1.3 in order to support the cache coherency model. Add header fields to matrix.  |
| 28.8.2012  | V2.41 | Joël Traber | Adding detailed description for SCMP Version concept.  |
| 08.10.2012 | V2.42 | Joël Traber | Adding header validation error for caching method value.   |



# Table of Contents

|        |  |    |
|--------|--|----|
| 1      | PREFACE.....                           | 5  |
| 1.1    | Purpose & Scope of this Document.....  | 5  |
| 1.2    | Definitions & Abbreviations.....       | 5  |
| 1.3    | External References.....               | 5  |
| 1.4    | Typographical Conventions.....         | 5  |
| 1.5    | Outstanding Issues.....                | 6  |
| 2      | COMMUNICATION SCHEMA.....              | 7  |
| 2.1    | Connection Topology.....               | 7  |
| 2.2    | Network Security.....                  | 8  |
| 2.3    | Network Connection Monitoring.....     | 10 |
| 2.4    | Load balancing.....                    | 11 |
| 2.5    | Failover.....                          | 11 |
| 2.6    | Intrusion and Virus Protection.....    | 11 |
| 3      | SERVICE MODEL.....                     | 12 |
| 3.1    | Session Services.....                  | 12 |
| 3.1.1  | Synchronous message delivery.....      | 12 |
| 3.1.2  | Asynchronous message delivery.....     | 13 |
| 3.1.3  | Large Messages.....                    | 14 |
| 3.1.4  | Multi Session Server.....              | 15 |
| 3.1.5  | Single Session Server.....             | 19 |
| 3.1.6  | Application Server (Tomcat).....       | 20 |
| 3.1.7  | Session Monitoring.....                | 20 |
| 3.1.8  | Server Monitoring.....                 | 21 |
| 3.1.9  | Abort and Restart Situations.....      | 22 |
| 3.1.10 | Server Allocation.....                 | 22 |
| 3.1.11 | Message Caching.....                   | 22 |
| 3.1.12 | Message Sequencing.....                | 24 |
| 3.2    | Publishing Services.....               | 24 |
| 3.2.1  | Large Messages.....                    | 27 |
| 3.2.2  | Subscription Monitoring.....           | 28 |
| 3.2.3  | Server Allocation.....                 | 29 |
| 3.2.4  | Message Fan-Out.....                   | 29 |
| 3.2.5  | Message Sequencing.....                | 30 |
| 3.3    | File Services.....                     | 30 |
| 3.4    | HTTP Redirection Services.....         | 32 |
| 4      | CASCADED SERVICES.....                 | 34 |
| 4.1    | Session Service.....                   | 34 |
| 4.2    | Publishing Service.....                | 34 |
| 4.3    | File Service.....                      | 35 |
| 4.4    | Cascaded HTTP Redirection Service..... | 35 |
| 4.5    | Service Routing.....                   | 35 |
| 5      | STATE DIAGRAMS.....                    | 37 |
| 5.1    | Client.....                            | 37 |
| 5.2    | Server.....                            | 38 |
| 6      | RELATIONSHIP DIAGRAM.....              | 39 |
| 6.1    | Client.....                            | 39 |
| 6.2    | Server.....                            | 39 |
| 7      | MESSAGE STRUCTURE.....                 | 40 |
| 7.1    | Headline.....                          | 40 |

|      |                                      |    |
|------|--------------------------------------|----|
| 7.2  | Header.....                          | 41 |
| 7.3  | Body .....                           | 42 |
| 7.4  | SCMP over TCP/IP .....               | 42 |
| 7.5  | SCMP over HTTP .....                 | 42 |
| 8    | SCMP MESSAGES.....                   | 44 |
| 8.1  | Keep-alive.....                      | 44 |
| 8.2  | ATTACH (ATT).....                    | 44 |
| 8.3  | DETACH (DET).....                    | 44 |
| 8.4  | INSPECT (INS).....                   | 45 |
| 8.5  | MANAGE (MGT).....                    | 45 |
| 8.6  | CLN_CREATE_SESSION (CCS) .....       | 46 |
| 8.7  | CSC_CREATE_SESSION (XCS).....        | 47 |
| 8.8  | SRV_CREATE_SESSION (SCS) .....       | 47 |
| 8.9  | CLN_DELETE_SESSION (CDS).....        | 48 |
| 8.10 | CSC_DELETE_SESSION (XDS) .....       | 48 |
| 8.11 | SRV_DELETE_SESSION (SDS).....        | 49 |
| 8.12 | SRV_ABORT_SESSION (SAS) .....        | 49 |
| 8.13 | REGISTER_SERVER (REG).....           | 49 |
| 8.14 | CHECK_REGISTRATION (CRG) .....       | 50 |
| 8.15 | DEREGISTER_SERVER (DRG).....         | 50 |
| 8.16 | CLN_EXECUTE (CXE).....               | 51 |
| 8.17 | CSC_EXECUTE (XXE).....               | 51 |
| 8.18 | SRV_EXECUTE (SXE).....               | 52 |
| 8.19 | ECHO (ECH) .....                     | 52 |
| 8.20 | CLN_SUBSCRIBE (CSU).....             | 53 |
| 8.21 | CSC_SUBSCRIBE (XSU).....             | 54 |
| 8.22 | SRV_SUBSCRIBE (SSU) .....            | 54 |
| 8.23 | CLN_CHANGE_SUBSCRIPTION (CHS) .....  | 54 |
| 8.24 | CSC_CHANGE_SUBSCRIPTION (XHS).....   | 55 |
| 8.25 | SRV_CHANGE_SUBSCRIPTION (SHS).....   | 56 |
| 8.26 | CLN_UNSUBSCRIBE (CUN) .....          | 56 |
| 8.27 | CSC_UNSUBSCRIBE (XUN) .....          | 57 |
| 8.28 | SRV_UNSUBSCRIBE (SUN).....           | 57 |
| 8.29 | CSC_ABORT_SUBSCRIPTION (XAB).....    | 57 |
| 8.30 | SRV_ABORT_SUBSCRIPTION (SAB).....    | 58 |
| 8.31 | RECEIVE_PUBLICATION (CRP) .....      | 58 |
| 8.32 | PUBLISH (SPU).....                   | 59 |
| 8.33 | FILE_DOWNLOAD (FDO) .....            | 59 |
| 8.34 | FILE_UPLOAD (FUP) .....              | 60 |
| 8.35 | FILE_LIST (FLI) .....                | 60 |
| 9    | SCMP HEADER ATTRIBUTES .....         | 62 |
| 9.1  | actualMask (ams).....                | 62 |
| 9.2  | appErrorCode (aec).....              | 62 |
| 9.3  | appErrorText (aet) .....             | 62 |
| 9.4  | bodyType (bty) .....                 | 62 |
| 9.5  | cacheExpirationDateTime (ced) .....  | 63 |
| 9.6  | cacheId (cid) .....                  | 63 |
| 9.7  | cachePartNumber (cpn) .....          | 63 |
| 9.8  | cascadedMask (cma).....              | 63 |
| 9.9  | cascadedSubscriptionId (csi) .....   | 64 |
| 9.10 | compression (cmp).....               | 64 |
| 9.11 | checkRegistrationInterval (cri)..... | 64 |
| 9.12 | echoInterval (eci) .....             | 64 |
| 9.13 | immediateConnect (imc).....          | 65 |
| 9.14 | ipAddressList (ipl) .....            | 65 |
| 9.15 | keepaliveInterval (kpi) .....        | 65 |
| 9.16 | localDateTime (ldt) .....            | 66 |
| 9.17 | messageInfo (min).....               | 66 |



|      |   |    |
|------|---|----|
| 9.18 | messageSequenceNumber (msn).....              | 66 |
| 9.19 | messageType (mty) .....                       | 67 |
| 9.20 | mask (msk).....                               | 67 |
| 9.21 | maxConnections (mxc) .....                    | 67 |
| 9.22 | maxSessions (mxs).....                        | 68 |
| 9.23 | noData (nod) .....                            | 68 |
| 9.24 | noDataInterval (noi) .....                    | 68 |
| 9.25 | operationTimeout (oti) .....                  | 68 |
| 9.26 | portNr (pnr).....                             | 69 |
| 9.27 | rejectSession (rej).....                      | 69 |
| 9.28 | remoteFileName (rfn) .....                    | 69 |
| 9.29 | scErrorCode (sec).....                        | 69 |
| 9.30 | scErrorText (set) .....                       | 69 |
| 9.31 | scVersion (ver).....                          | 70 |
| 9.32 | serviceName (nam) .....                       | 70 |
| 9.33 | sessionId (sid) .....                         | 70 |
| 9.34 | sessionInfo (sin) .....                       | 71 |
| 9.35 | urlPath (urp) .....                           | 71 |
| 9.36 | appendixNumber (anr) .....                    | 71 |
| 9.37 | numberOfAppendix (nra).....                   | 71 |
| 9.38 | cachingMethod (cmt) .....                     | 71 |
| 10   | GLOSSARY.....                                 | 72 |
|      | APPENDIX A - MESSAGE HEADER MATRIX .....      | 74 |
|      | APPENDIX B – SC ERROR CODES AND MESSAGES..... | 78 |
|      | INDEX.....                                    | 79 |

## Tables

|         |                                  |   |
|---------|----------------------------------|---|
| Table 1 | Abbreviations & Definitions..... | 5 |
| Table 2 | External references.....         | 5 |
| Table 3 | Typographical conventions .....  | 5 |

## Figures

|           |   |    |
|-----------|---|----|
| Figure 1  | Communication Layers.....                             | 7  |
| Figure 2  | Connection Topology .....                             | 8  |
| Figure 3  | Network Security .....                                | 9  |
| Figure 4  | Synchronous Request/Response .....                    | 12 |
| Figure 5  | Synchronous Message Exchange.....                     | 13 |
| Figure 6  | Asynchronous Request/Response .....                   | 13 |
| Figure 7  | Asynchronous Message Exchange.....                    | 14 |
| Figure 8  | Large Request.....                                    | 14 |
| Figure 9  | Large Response.....                                   | 15 |
| Figure 10 | Multi Session server (immediateConnect = true). ..... | 16 |
| Figure 11 | Multi-Session server (immediateConnect = false).....  | 18 |
| Figure 12 | Execution exceeding operation timeout.....            | 19 |
| Figure 13 | Single Session Server .....                           | 20 |
| Figure 14 | Session Monitoring.....                               | 21 |
| Figure 15 | Server Monitoring.....                                | 21 |
| Figure 16 | Caching rules .....                                   | 23 |

---

|  |    |
|--|----|
| Figure 17 Message Caching .....                          | 24 |
| Figure 18 Subscribe / Publish .....                      | 25 |
| Figure 19 Publishing Service .....                       | 26 |
| Figure 20 Large Published Message .....                  | 28 |
| Figure 21 Subscription Monitoring .....                  | 29 |
| Figure 22 Message Fan-Out .....                          | 30 |
| Figure 23 File service.....                              | 31 |
| Figure 24 File upload and download.....                  | 31 |
| Figure 25 HTTP redirection service.....                  | 32 |
| Figure 26 HTTP redirection service.....                  | 32 |
| Figure 27 Cascaded Session Service (simplified) .....    | 34 |
| Figure 28 Cascaded Publishing Service (simplified) ..... | 34 |
| Figure 29 Cascaded File Service.....                     | 35 |
| Figure 30 Cascaded HTTP Redirection Service .....        | 35 |
| Figure 31 Service Routing .....                          | 36 |
| Figure 32 Client states for session service .....        | 37 |
| Figure 33 Client states for publishing service .....     | 37 |
| Figure 34 Server states for session service .....        | 38 |
| Figure 35 Server states with publishing service.....     | 38 |
| Figure 36 Client relationships .....                     | 39 |
| Figure 37 Single Session Server relationships .....      | 39 |
| Figure 38 Multi Session Server relationships .....       | 39 |
| Figure 39 Message Structure.....                         | 40 |
| Figure 40 Message Structure Example .....                | 40 |
| Figure 41 SCMP Version concept .....                     | 41 |

# 1

# Preface

## 1.1 Purpose & Scope of this Document

This document describes the SCMP (**SC** **M**essage **P**rotocol).

The final and approved version of this document serves as base for publication as Open Source.

This document is particularly important to all project team members and serves as communication medium between them.

## 1.2 Definitions & Abbreviations

| Item / Term | Definition / Description   |
|-------------|--|
| HTTP        | Hypertext Transport Protocol   |
| HTTPS       | HTTP over SSL, encrypted and authenticated transport protocol                          |
| Java        | Programming language and run-time environment from SUN                                 |
| JDK         | Java Development Kit   |
| Log4j       | Standard logging tool used in Java   |
| OpenVMS     | HP Operating system  |
| RMI         | Remote Method Invocation - RPC protocol used in Java                                   |
| RPC         | Remote Procedure Call  |
| SOAP        | Simple Object Access Protocol  |
| SSL         | Secure Socket Layer – secure communication protocol with encryption and authentication |
| TCP/IP      | Transmission Control Protocol / Internet Protocol                                      |
| SC          | Service Connector  |
| USP         | Universal Service Processor – predecessor of SC  |
| Wireshark   | Open source product to capture and analyze network traffic                             |

**Table 1 Abbreviations & Definitions**

## 1.3 External References

| References | Item / Reference to other Document  |
|------------|---|
| [1]        | SC_0_Specification_E – Requirement and Specifications for Service Connector |
| [2]        | SC_CC_E-V1.1  |

**Table 2 External references**

## 1.4 Typographical Conventions

| Convention             | Meaning   |
|------------------------|---|
| <i>text in italics</i> | features not implemented in the actual release                        |
| text in Courier font   | code example  |
| [ phrase ]             | In syntax diagrams, indicates that the enclosed values are optional   |
| { phrase1   phrase2 }  | In syntax diagrams, indicates that multiple possibilities exists.     |
| ...                    | In syntax diagrams, indicates a repetition of the previous expression |

**Table 3 Typographical conventions**

The terminology used in this document may be somewhat different from other sources. The chapter Glossary includes a list of often used terms with the explanation of their meaning in this document.

## 1.5 Outstanding Issues

Following issues are outstanding at the time of the document release:

- none

## 2

# Communication Schema

The SC supports message exchange between requesting application (client) and another application providing a service (server). The client and the server are the logical communication end-points. The SC never acts as a direct executor of a service. The client can communicate to multiple services at the same time.

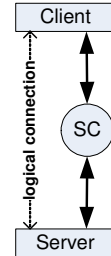

Server application can provide one or multiple service. Serving multiple services within one application is possible only for multithreaded or multisession servers. Multiple server applications are running on the same server node, each providing different service. All services are independent on each other. Server application may request another service and so play the client role.

The SC implements peer-to-peer messaging above OSI layer-7 (application) network model between client and server applications. The SC is always in between the communicating partners, controlling the entire message flow.

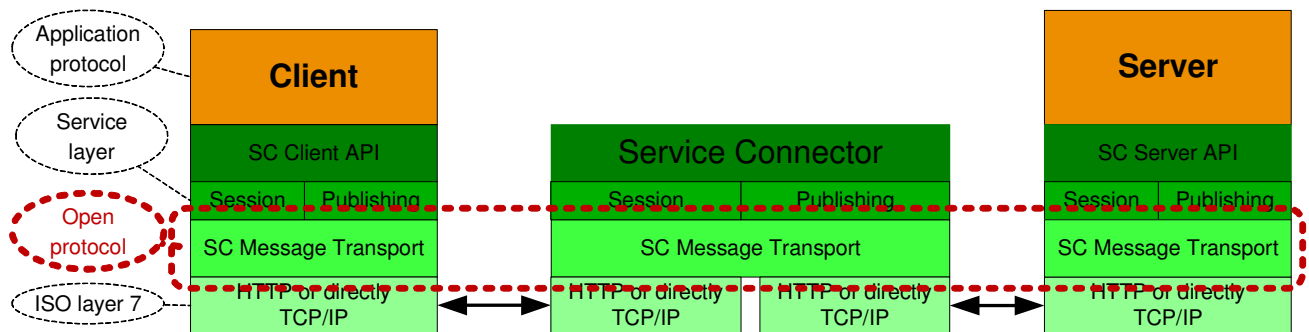

**Figure 1 Communication Layers**

The SC acts like a broker, passing messages between the client and the server. The communicating parties must agree on the application protocol i.e. format and content of the message payload.

### 2.1 Connection Topology

Client application, server application and the SC may reside on the same node or on separate nodes. The connection can either utilize HTTP protocol or direct TCP/IP communication. No assumption about the physical network topology is done. Multiple firewalls can be located on the path between the communicating partners. The SC supports following connection topology:

- Client ⇔ SC ⇔ Server = Direct connection
- Client ⇔ SC ⇔ SC ⇔ Server = Connection via cascaded SC.  
Multiple SC may be placed on the path between the client and service.

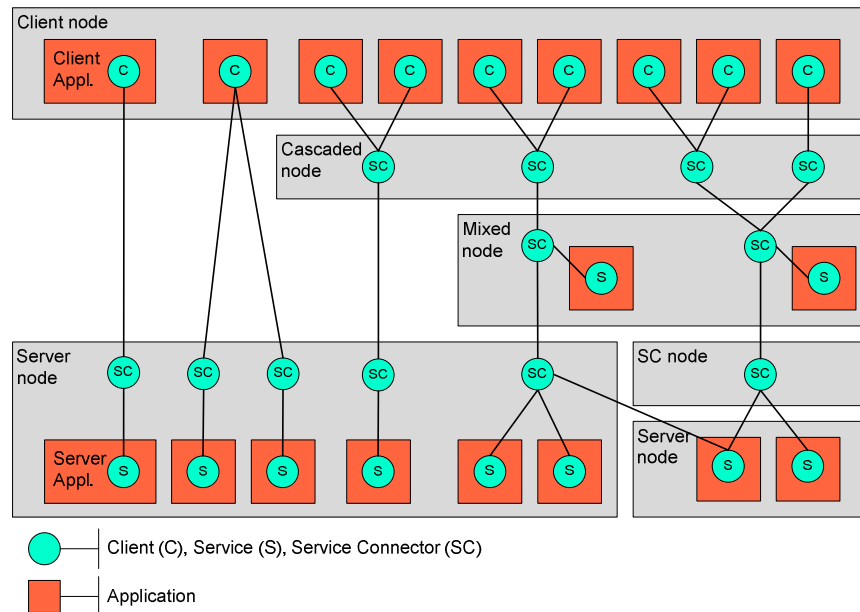

**Figure 2 Connection Topology**

Different connection topology types from left to right:

1. Client connected to one service
2. Client connected simultaneously to SCs and two services
3. Two clients connected to one service via cascaded service and cascaded SC
4. Two clients connected to three services via cascaded service on different server nodes
5. Complex configuration with three clients connected to three services on different server nodes via cascaded SCs and SC offloaded to its own node. One server can be registered to multiple services and different SCs. However this is possible for multisession servers only.

**Limitation:** The same service can be accessed by one SC only. When the same service should be used on different nodes, it must have a different name (e.g. node suffix).

Two different transport types can be individually configured for each network segment i.e. between the Client ↔ SC, SC ↔ SC or SC ↔ Server.

- a. HTTP  
Such connection may pass screening firewalls and is appropriate for communication within the customer organization e.g. Client ↔ SC or SC ↔ SC.
- b. TCP/IP  
Such connection would not pass firewalls without explicit security rules. It is useful for connection within the same node e.g. SC ↔ Server.

SC cascading is used for performance and/or for security reasons. It is transparent for the application.

## 2.2 Network Security

The SC does not implement any security feature. The environment where SC is used must provide all required authentication, authorization, encryption, tunneling etc. features. Message transport over https will not be supported.

The IP address of the client and the IP of the incoming TCP/IP traffic will be available in the message header and can be evaluated by the server. This can be used to authenticate and authorize the client when VPN tunnel is used. From the security viewpoint, the number of clients or server is not relevant. Meaningful are connections between nodes and security

measures taken to protect legal subjects to which the particular network segment belongs. The following schema shows some possible networks that may be configured to pass SC messages.

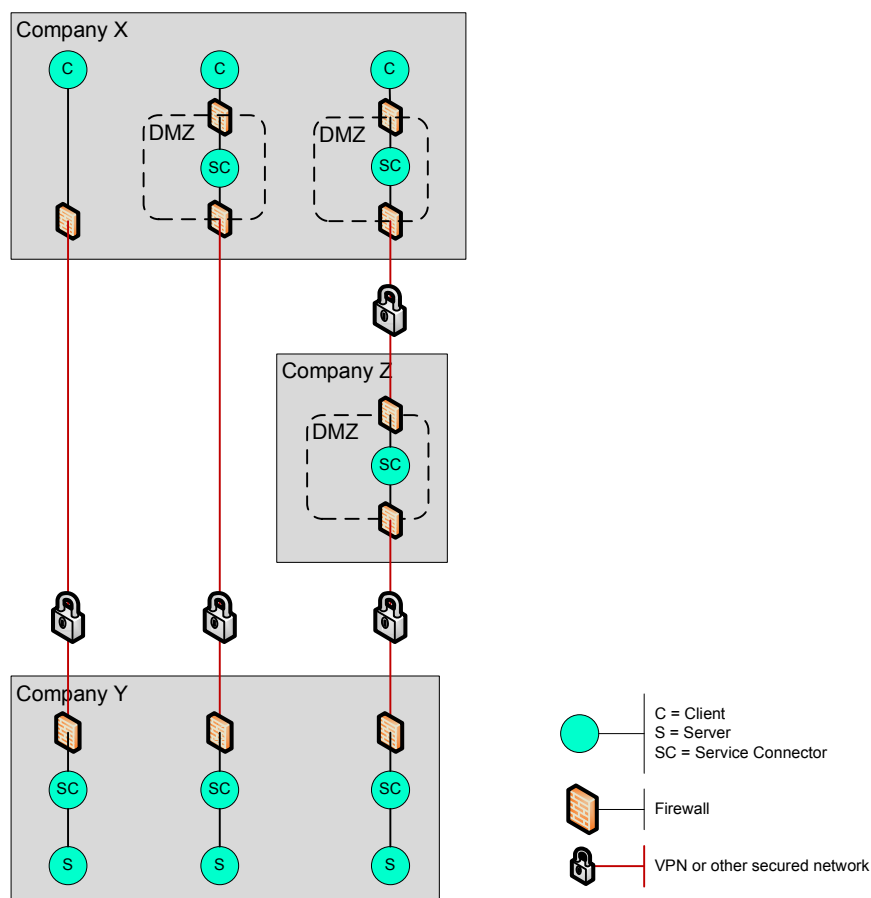

**Figure 3 Network Security**

*Protocol*

The message transport between each of the SC components (green bullet) may be configured as plain TCP/IP or HTTP. The connection is always initiated by the client (top-down in the picture above). The client defines which transport (TCP/IP or HTTP) it will use. The transport protocol between SC and the next downstream component is configured in the SC configuration. TCP/IP is strongly recommended between SCs through VPN tunnels as well as between SC and the Server for performance reasons. HTTP is recommended between the client and SC. For connection between SC and Web Server or Application Server (Tomcat) only HTTP can be used.

*Firewall*

Firewall with a proper configuration may be placed on any path between two SC components. Firewall between SC and the server is possible, but not recommended for performance reasons. For HTTP protocol the firewall can be configured to perform [statefull packet inspection](#) with HTTP filtering. For TCP/IP the appropriate port must be configured in the firewall.

When the message traffic will pass a firewall, HTTP protocol is recommended. In such case the SC can be seen as a regular Web-Server. The firewall can be configured to perform [statefull packet inspection](#) with HTTP filtering. For connection between SC and the server and for communications though VPN tunnels direct TCP/IP is recommended for performance reasons.

When HTTP connection is used and multiple parallel requests are in progress, SC will create multiple connections for each pending request in order to keep them balanced and so satisfy firewall inspection rules. (Statefull inspection rejects two subsequent GET/POST request without response from the server)

*IP address list* Multiple SCs may be placed on the communication path between the client and the server. In order to allow comprehensive authorization all IP addresses are collected and made available to the server as a list. The list contains of IP addresses in the form 999.999.999.999. The order in the list has a dedicated meaning. The list has at least three entries.

1. IP of the client at Company X
2. Incoming IP received by SC = IP of the VPN Tunnel
3. IP of the SC at Company Y

Client connected via cascaded SC placed in company's X DMZ will have the list in the format:

1. IP of the client at Company X
2. Incoming IP received by SC in company's X DMZ.
3. IP of the SC in company's X DMZ
4. Incoming IP received by SC = IP of the VPN Tunnel.
5. IP of the SC at Company Y

If the pairs 1,2 or 3,4 have different values, then the corresponding network segment uses VPN or NAT. As long as there is only one SC behind the VPN, the second last address is always the tunnel IP used for authentication.

## 2.3 Network Connection Monitoring

*Connection pool* The network connections between client ↔ SC, SC ↔ SC or SC ↔ server is managed in a connection pool. Connection pool can be either static or dynamic. When static pool is created (*immediateConnect* = true) all connections are created immediately and never closed. When dynamic pool is created (*immediateConnect* = false) connections are created when the first session is started and closed when they are idle for a long time i.e. several subsequent keep alive messages have been sent. Small number of connections is kept open for all times. When necessary, new connections are created on the fly. The same connection from a static or dynamic pool is reused unless it is busy. When the server deregisters, the connection pool is deleted and all existing connections are closed.

*Keep-alive* Keep-alive messages are sent in regular intervals on all idle connections initiated by a network peer (client, server or SC). They are not sent on busy connections currently used for message exchange. E.g. while client or publishing server is waiting for response, the connection is busy and no keep-alive message will be sent. With http connection statefull firewall inspection would reject two subsequent GET/POST request without previous response from the server in such case. Using of keep-alive messages can be disabled by setting the *keepaliveInterval* = 0.

The only purpose of keep-alive messages is to preserve the connection state in the firewall placed between the communicating peers and resets its internal timeout. Keep alive message is always initiated by the peer who has initiated the connection (client, server or SC), because only outbound traffic may refresh the firewall timeout.

Client connections used for session or file services are mostly idle and will utilize the keep-alive mechanism. Client connections used for publishing services are mostly busy. The mechanism to refresh the firewall timeout is built in the SCMP layer.

Server connections used for registering server are mostly idle and will utilize the keep-alive mechanism. SC connections back to the server are also mostly idle and will utilize the keep-alive mechanism.

When a connection breaks down because of an error while sending or receiving a keep-alive message, or the response does not timely arrive a log entry is created, the connection is closed and deleted from the pool. **No error is signalled to the application.**

Broken network connection between the server and SC on which the server has registered to the service is detected in SC and an immediate server cleanup is done. This speeds up the detection of lost or dead servers.

The keep-alive message has only a headline and no attributes and no body. The format is:



KRQ 0000000 00000 1.3

for request and:

KRS 0000000 00000 1.3

for response.

## 2.4 Load balancing

The SC does not provide any load balancing features. Established communication session will not be redirected to another server node during its life time.

## 2.5 Failover

The SC does not provide any failover features. Aborted communication must be re-established by the communicating partners. The client application must find out a service which is alive.

## 2.6 Intrusion and Virus Protection

The entire network where SC is used is assumed to be safe and secure. No virus protection is embedded in SC. The customer may use screening firewall to protect the SC components. It is recommended to use SC within a DMZ.

SC is not designed to withstand network attacks like DOS or SYNC flood, or any other.

# 3

## Service Model

The SC supports message exchange between requesting application (client) and another application providing a service (server). The client and the server are the logical communication end-points. The SC never acts as a direct executor of a service. The client can communicate to multiple services at the same time.

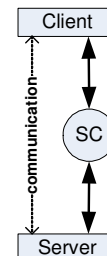

Multiple clients may request the same service at the same time. Parallel execution of the service is implemented by starting multiple server instances (multiprocessing), by starting a multisession server (multithreading) or by a combination of both. The server process can provide one or multiple service and decides how many sessions it can serve. Serving multiple services within one server process is possible for multisession servers only.

All services are independent on each other. Server application may request another service and so play the client role.

### 3.1 Session Services

This is a statefull Request/Response service initiated by the client. For session services the client and the server exchange messages in context of a logical session through the SC.

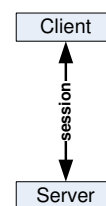

The client controls the creation and deletion of the session and so allocation of the server. The client can have multiple concurrent sessions to the same or to different services. **Because the server execution is always synchronous, from the client perspective only one pending request per session is possible at any time.**

When a session is created SC will choose a free server and pass this and all subsequent requests within this session to the same server. Session information is passed in each message as a part of the message header. Session is deleted intentionally by the client or aborted by SC upon an error.

#### 3.1.1 Synchronous message delivery

The client sends a request to a service that invokes an application code. Upon completion the service sends back a response message. The client waits for the arrival of the response message. The request and response message length are not limited in size.

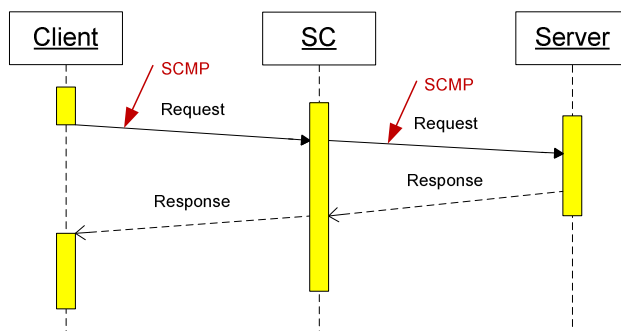
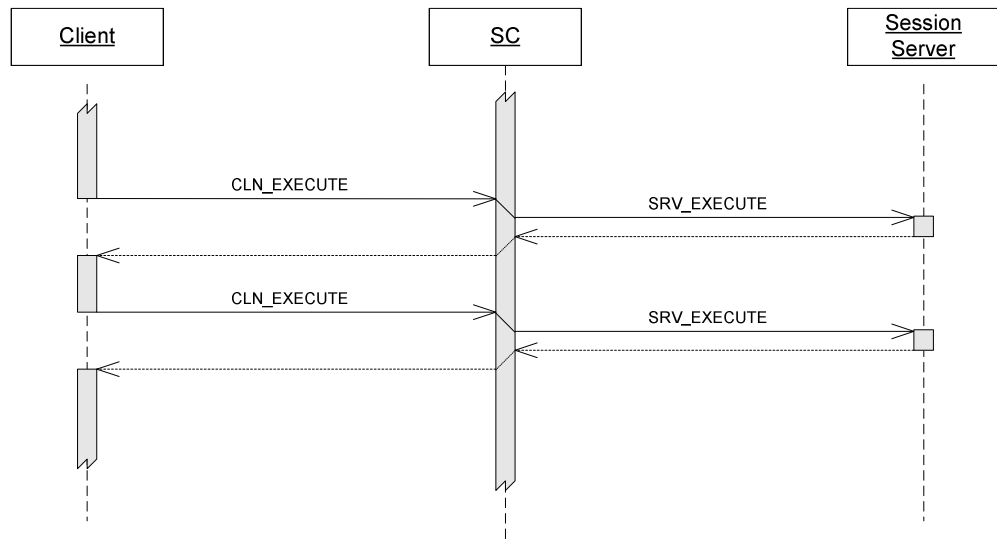

Figure 4 Synchronous Request/Response

This communication style is the most often used for getting data from the server or sending a message that triggers a transaction on the server.

The message flow looks as follows:



**Figure 5 Synchronous Message Exchange.**

### 3.1.2 Asynchronous message delivery

Asynchronous execution is functionally equal to the synchronous case with the exception that the client does not wait for the arrival of the response message. Fully asynchronous message exchange is not possible because the server execution is always synchronous. For this reason only the receipt of the server response can be asynchronous.

The client must declare a notification method that is invoked when the response message arrives.

*Note!*

**Only one pending request per session is allowed at any time. Subsequent client request must be hold in by the client API until the response for the previous message arrives.**

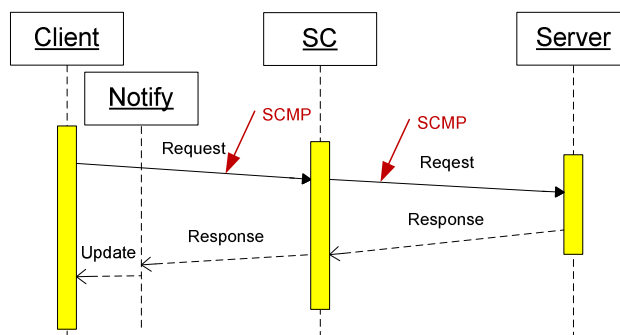

**Figure 6 Asynchronous Request/Response**

This communication style will be used to load data while other activities are in progress, e.g. to get large amount of static data at startup. It can be also used as fire-and-forget when the response is not meaningful. The message flow looks as follows:

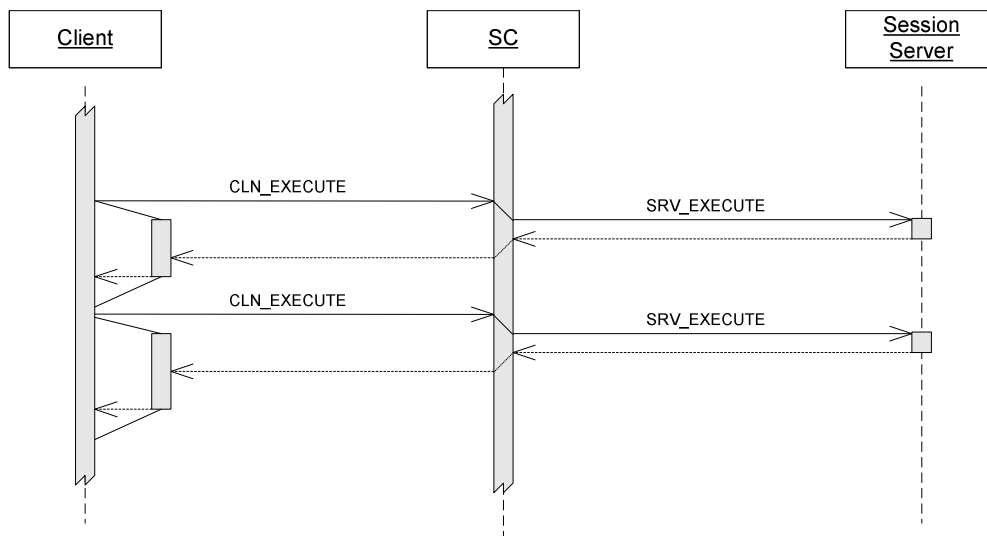

Figure 7 Asynchronous Message Exchange.

### 3.1.3 Large Messages

Regular request / response messages have a REQ / RES headerKey in the head line. Large messages are broken into parts with its own headerKey PRQ (part request) and PAC (part acknowledge). For large request the message flow looks as follows:

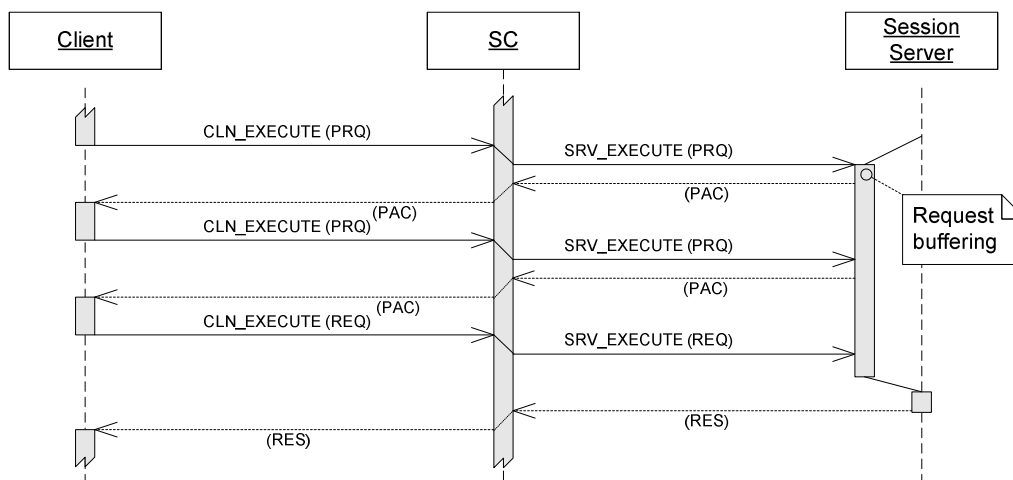
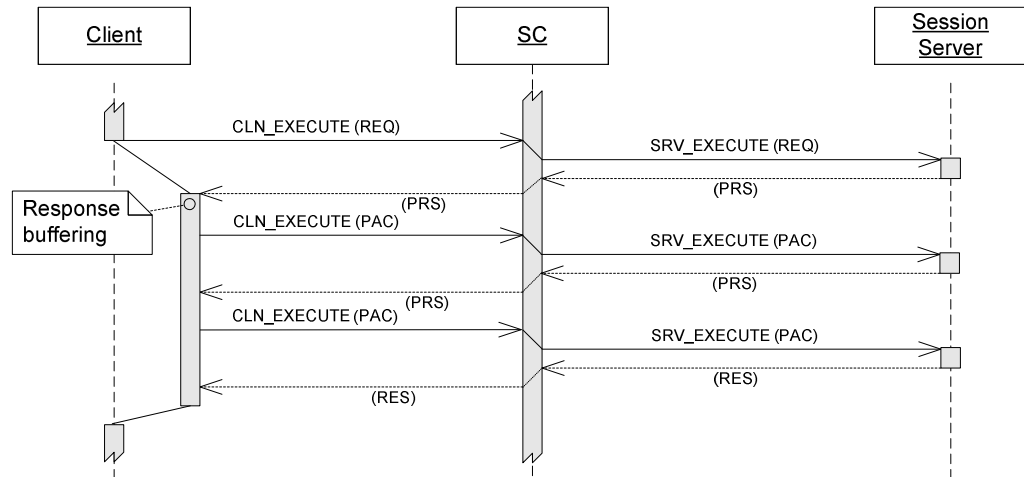

Figure 8 Large Request.

1. The client sends the first the message part (PRQ) to the server.
2. The message part is transported to the server and buffered here
3. The server answers with PAC in order to receive the next part.
4. When the final message part (REQ) arrives, the complete message is made available to the server.
5. The sever will process the message and send back the response message (RES).

For large response the message flow looks as follows:



**Figure 9 Large Response.**

1. The client sends a request message (REQ) to the server.
2. The server receives the request messages and start producing the response. It sends part message (PRS) to the client and keeps the context.
3. The client receives the partial response (PRS) and starts buffering of the data. It sends part acknowledge (PAC) in order to receive more results from the server.
4. At the end the server sends the last message part as a regular response (RES)
5. When the final response arrives, the message is made available to the client.

Combination of large request and large response is also possible.

Message traffic with large request followed by a large response looks like (simplified):

```

REQ .. msn=3
RES .. msn=64
...
PRQ .. msn=4
PAC .. msn=65
PRQ .. msn=5
PAC .. msn=66
PRQ .. msn=6
PAC .. msn=67
REQ .. msn=7
PRS .. msn=68
PAC .. msn=8
PRS .. msn=69
PAC .. msn=9
RES .. msn=70
...
REQ .. msn=10
RES .. msn=71

```

### 3.1.4 Multi Session Server

Multi session server serves multiple sessions at the same time. SC uses a dynamic connection pool to exchange messages with the server. The server registers itself for one or more services and defines reasonably high *maxSessions* > 1 and *maxConnections* > 1. Depending on the *immediateConnect* flag static or dynamic connection pool to the server is created. When static pool is created (*immediateConnect* = true) all connections are created immediately and never closed. When dynamic pool is created (*immediateConnect* = false) connections are created when the first session is started and closed when they are idle for a long time i.e. several

subsequent keep alive messages have been sent. Small number of connections is kept open for all times. When necessary, new connections are created on the fly. The same connection from a static or dynamic pool is reused unless it is busy. When the server deregisters, the connection pool is deleted and all existing connections are closed.

The attribute *maxConnections* specified in server registration tells the SC how many connections should be created and so limits the pool size. This allows network resource optimization when one server serves many rarely used sessions. When all connections in the pool are exhausted, SC will wait for a free connection and finally return an error to the client.

The following schema shows message flow with multi session server with *immediateConnect = true*..:

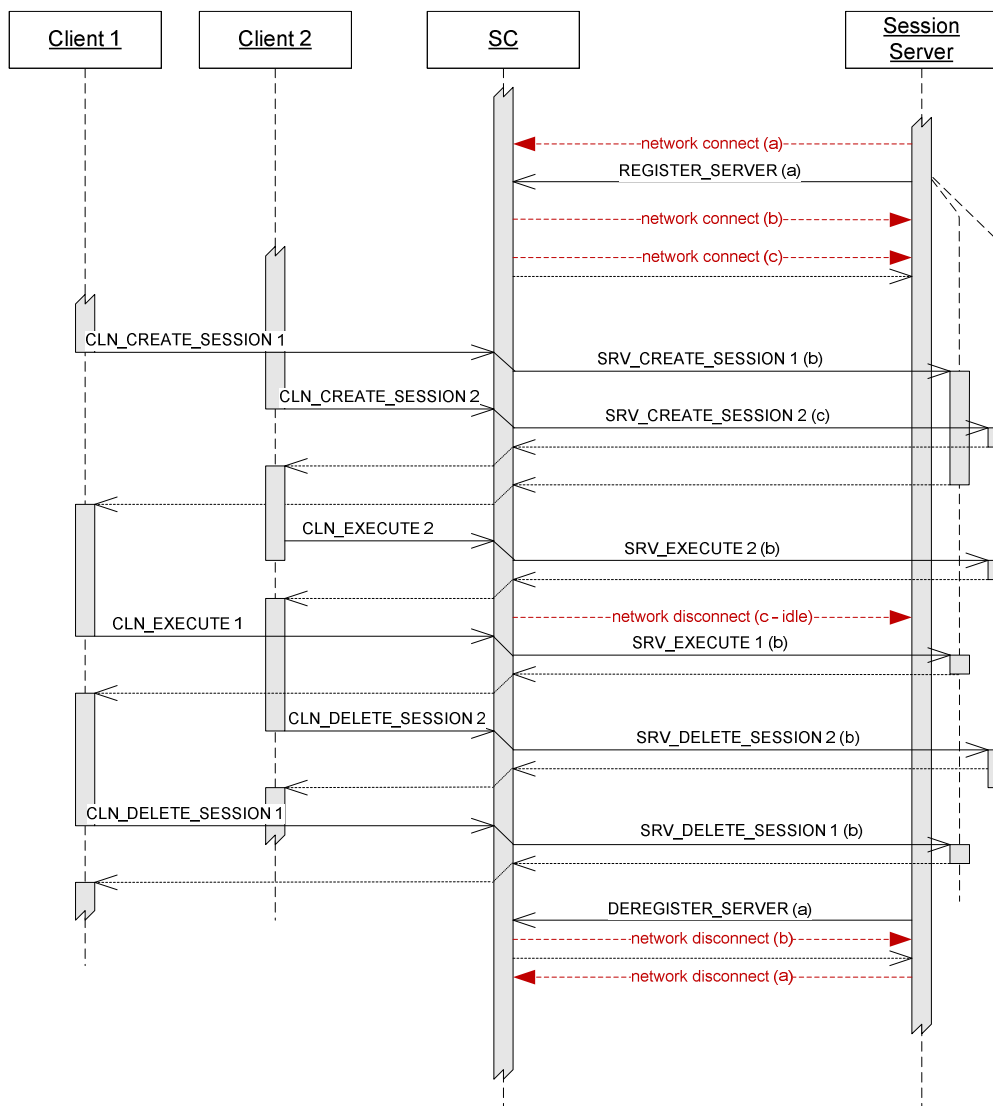

**Figure 10 Multi Session server (immediateConnect = true).**

*Client*

1. The client establishes a network connection to SC and starts communication with the ATTACH message.
2. Then it starts a session with a service with the CLN\_CREATE\_SESSION message
3. The SC allocates a server providing this service and notifies it about the session start with the SRV\_CREATE\_SESSION message. It also creates a unique sessionId for this session. If there is no free server instance available to this service, the SC will retry several times and finally returns an error.

4. Then the client can exchange messages with the server via CLN\_EXECUTE messages.
5. When the session with this service is no longer needed, the client will send the CLN\_DELETE\_SESSION message. The server is notified with the SRV\_DELETE\_SESSION message.
6. Before the client terminates, it should send DETACH message and then terminate the network connection to SC.

When session is abnormally terminated, the client will receive an error message in the response to next request (regular message or echo). The reasons for this can be:

- Server sends Deregister\_Server
- Unexpected server exit
- Underlying communication error (e.g. unreachable node)

**Note**

**The client may have multiple SCs connected at the same time. Per connected SC it may have multiple active sessions (even for the same service) at the same time. From the client perspective only one request may be pending at any time for a session.**

**Server**

1. The server establishes a network connection (a) to SC and starts communication and registers itself as an instance of a service with the REGISTER\_SERVER message. At that time it should have a listener that will accept the connection (b) initiated by the SC to this server.
2. The SC registers the server instance and will create network connection (b) and (c) back to it. Keep-alive messages will also be sent on these connections, depending on the *keepaliveInterval* set in REGISTER\_SERVER.
3. When a client creates a session, the server is notified with the SRV\_CREATE\_SESSION message. The message contains additional information about the client and the sessionId. The server can accept or reject the session.
4. The server receives messages from the client as SRV\_EXECUTE and sends them back after execution of the service that it implements. The server receives requests on any of the network connections created by SC. It may use any available technique (e.g. multithreading), but must ensure that all requests are processed in parallel.
5. When the client deletes the session, the appropriate server is notified with the SRV\_DELETE\_SESSION message.
6. When the server is no longer needed it sends the message Deregister\_Server. From this point the SC will not allocate it for a session and terminates the connection (b) and (c) to it. Then it can terminate the network connection (a) to SC.

When the session is abnormally terminated, the server is notified with the SRV\_ABORT\_SESSION message. The reasons for this can be:

- Unexpected client exit and the subsequent expiration of the echo timeout
- Underlying communication error (e.g. unreachable node)

The network connection (a) must not be dropped until Deregister\_Server message is sent. Otherwise SC will treat this as server termination and clean-up all its sessions and its registration.

**Note**

**The server must be active before the client will create a session. Otherwise the client will receive an error message.**

With flag *immediateConnect* = false connections are created by SC when the session is started. The same connection is reused unless it is busy. Connections are closed when they are idle for long time. The last active connection is closed when the session is deleted or aborted.

The following schema shows message flow with multi session server with *immediateConnect* = false:

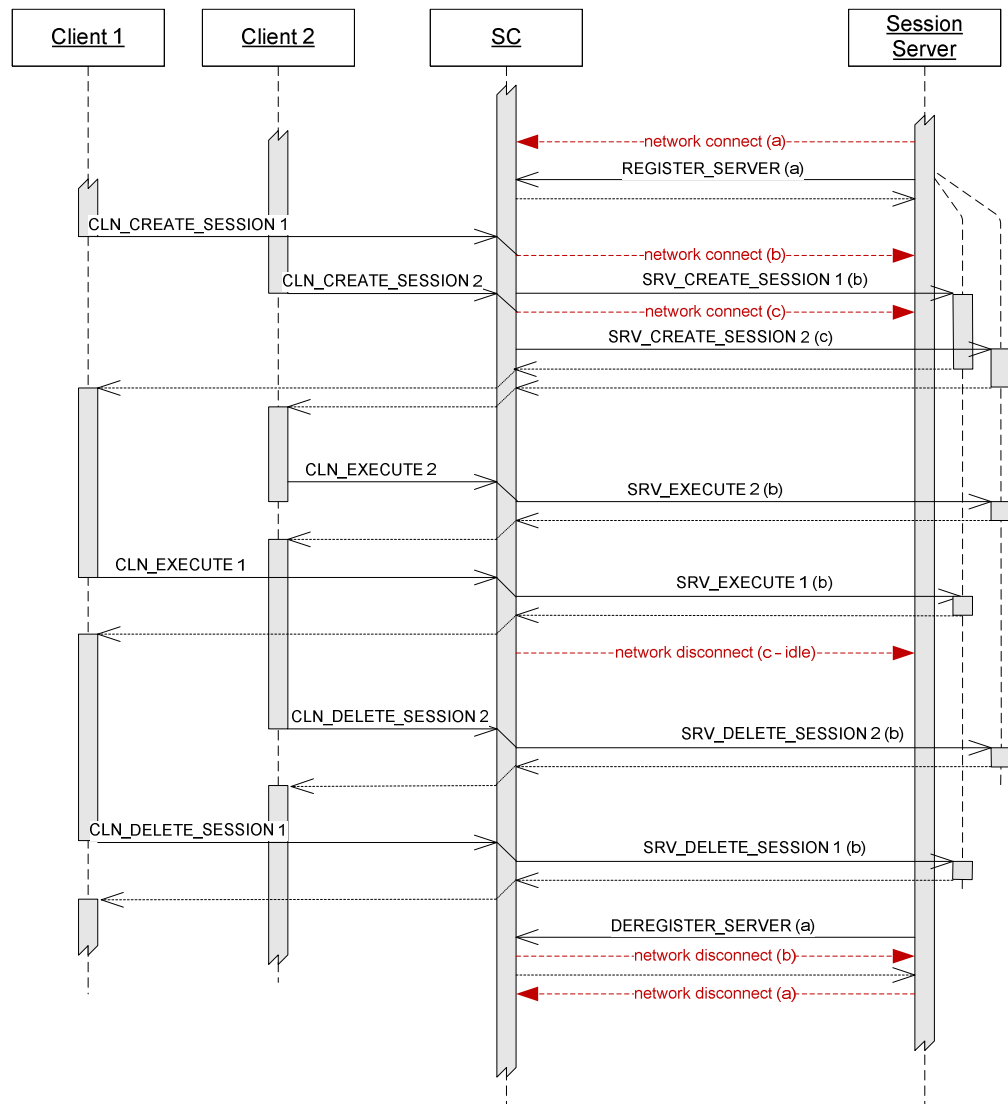

**Figure 11 Multi-Session server (immediateConnect = false).**

The network connection (a) must not be dropped until `DEREGISTER_SERVER` message is sent. Otherwise SC will treat this as server termination and clean-up all its sessions and registration.

**Note!**

**The request execution on the server may take long time. In case the operation timeout (set by the client) expires, the SC will close the connection to the server on which the `SRV_EXECUTE` request was sent and send `CLN_EXECUTE` error message back to the client. SC will NOT abort the session! The client should react properly in this situation and close the session. In case it will send a subsequent `CLN_EXECUTE` to the server, the previous execution may still be pending!**

The message flow looks as follows:



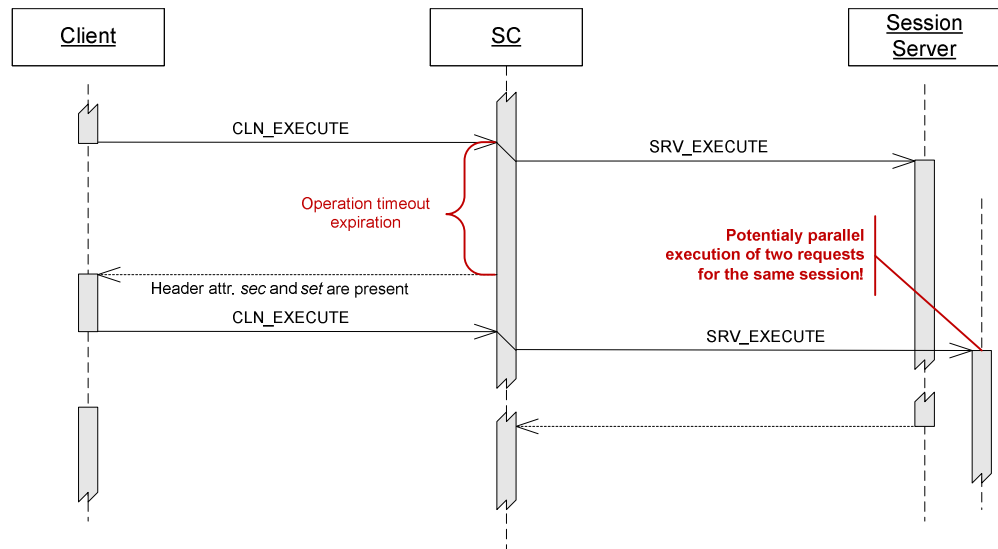

Figure 12 Execution exceeding operation timeout.

### 3.1.5 Single Session Server

Single-session behaves like a multi session server but has only one session and one connection. It registers itself for one service and may serve only one session at the same time. It must define *maxSessions = 1*, *maxConnections = 1* and may define *immediateConnect = true* or *false*. The required parallelism is achieved by starting multiple instances of the same server. The SC keeps track of the registered servers and allocates / de-allocates sessions to them. The following schema shows message flow with single session server.

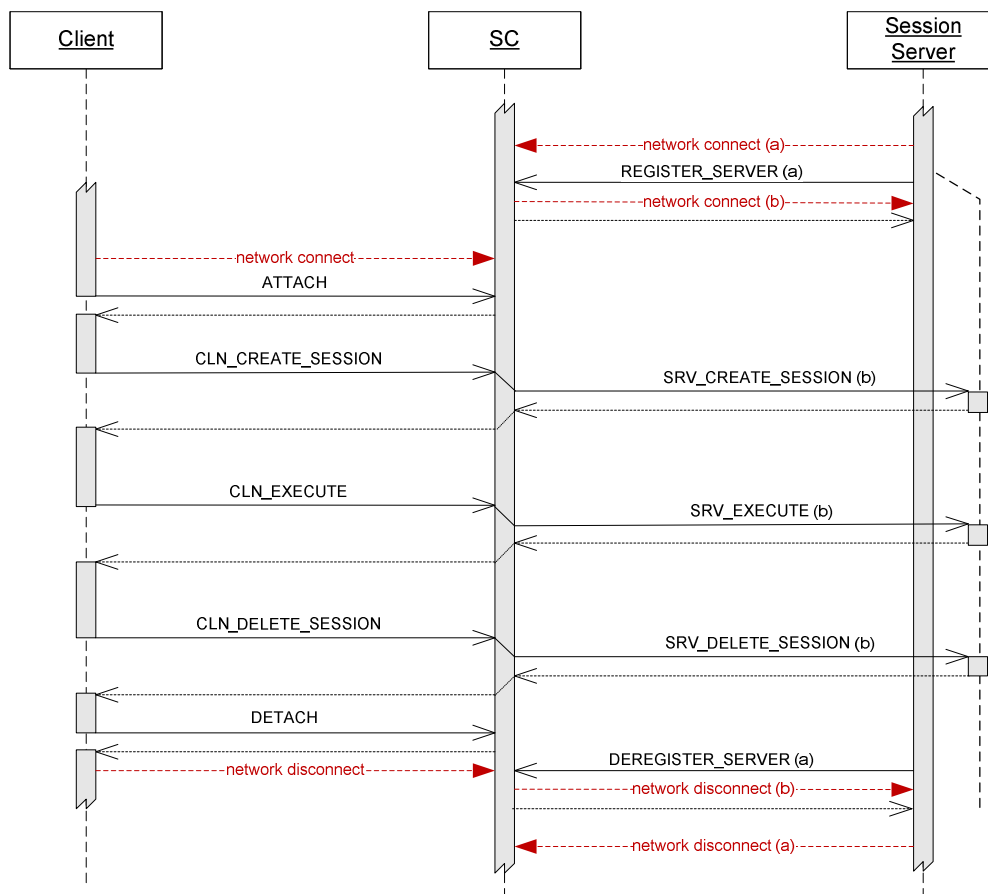

Figure 13 Single Session Server

**Note!**

The request execution on the server may take long time. In case the operation timeout (set by the client) expires, the SC will close the connection to the server on which the SRV\_EXECUTE request was sent and send CLN\_EXECUTE error message back to the client. SC will NOT abort the session! The client should react properly in this situation and close the session. In case it will send a subsequent CLN\_EXECUTE to the server, the previous execution may still be pending!

### 3.1.6 Application Server (Tomcat)

SCMP messaging with an application server (e.g. Tomcat) works exactly like a multi session server but utilizes the HTTP protocol between server and SC. The server must register itself for all services it will serve. It must define reasonable high *maxSessions* and *immediateConnect = false*. It is recommended to define also a reasonable high *maxConnections* attribute.

### 3.1.7 Session Monitoring

Session monitoring is based on ECHO messages, exchanged periodically for each active session between the client and the SC. Session monitoring is not related to the keep-alive messages exchanged on active network connections. The client sends ECHO message in predefined intervals for each session service. The *echoInterval* is extended by *echoIntervalMultiplier* in order to allow time for network transmission. The client receives an ECHO response message back from the SC. The SC monitors time between two subsequent ECHO messages and aborts the session when the interval is exceeded. SRV\_ABORT\_SESSION message is sent to the allocated server in such case. During regular EXECUTE messages the *echoInterval* is extended by the *operationTimeout* in order to prevent session expiration during long server processing.

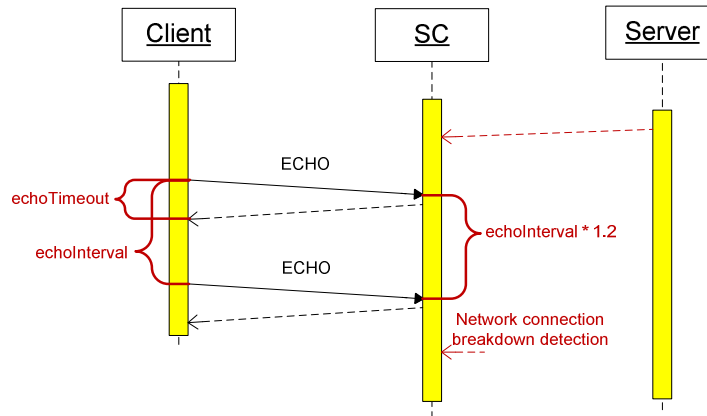

**Figure 14 Session Monitoring**

Based on the *operationTimeout* SC monitors the server response time. When this timeout expires for *SRV\_EXECUTE*, SC will notify the client but will NOT clean up the session. It may still be valid, just the server may be very slow. When the timeout expires for *SRV\_CREATE\_SESSION*, the session is not created. When the timeout expires for *SRV\_DELETE\_SESSION*, or *SRV\_ABORT\_SESSION* the session is deleted.

The session maintained in SC will be deleted only due to these reasons:

1. The client deliberately closes the session by sending *CLN\_DELETE\_SESSION*
2. The SC will not receive ECHO from the client, for longer than the *echoInterval \* echoIntervalMultiplier*.
3. The server crashes and loses connection to the SC

### 3.1.8 Server Monitoring

Server monitoring is based on *CHECK\_REGISTRATION* messages, exchanged periodically between the registered server and the SC. Server monitoring is not related to the keep-alive messages exchanged on active network connections. The server sends *REGISTRATION* message in predefined intervals to the SC. The *checkRegistrationInterval* is extended by *checkRegistrationIntervalMultiplier* in order to compensate network latency. The server receives a *CHECK\_REGISTRATION* response message back from the SC. The SC monitors the time between two subsequent *CHECK\_REGISTRATION* messages and aborts the server when the interval is exceeded. *PUBLISH* message sent by a publishing server resets also the timer in SC.

On server abort all sessions or subscriptions allocated to it are cleaned up. When the client sends a request message related to the deleted session or subscription, it will get an error response.

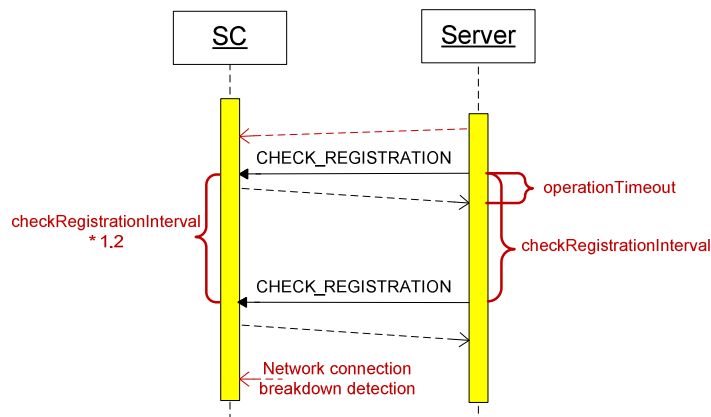

**Figure 15 Server Monitoring**

Server monitoring can be disabled by defining *checkRegistrationInterval = 0*. Server can send *CHECK\_REGISTRATION* messages at any time.

### 3.1.9 Abort and Restart Situations

- Client* When client aborts its activity abruptly while a request is pending, then SC will not be able to deliver the response. The SC will be clean up the session and the server will be notified with `SRV_ABORT_SESSION` message.
- When idling client aborts its activity abruptly, then SC will not detect the session breakdown before the *echoInterval* is exceeded. During this time new sessions can be created by the restarted client. Old sessions may still exist in SC some time until they will expire. Consequently the server may be still allocated and may receive `SRV_ABORT_SESSION` message for the old session after the `SRV_CREATE_SESSION` for the new session.
- When idling client loses all connections to SC due to short temporary network unavailability, then the connection may be re-established without loss of the sessions. This is true only if the breakdown is shorter than the *echoInterval*, and no other message is sent to SC in the mean time. This does not work for publishing clients which detect the connection loss immediately due to the pending operation.
- Server* When server aborts its activity abruptly (without a neat deregister), then SC will detect the connection breakdown immediately (on the connection on which the server registers) and will clean up all its sessions. Subsequent client messages for the deleted sessions may cause an error. After server restart, new connections to and from SC will be established. The server can then be allocated to new sessions.
- SC* When SC crashes, client will detect the connection breakdown when a new message is sent. It should perform cleanup followed by a reconnect. The server will detect the connection SC breakdown on the connection on which it listens and should perform a cleanup followed by reconnect and service registration.
- After SC restart, new connections will be established. The servers must register before the client starts new session. Otherwise the client gets an error.

### 3.1.10 Server Allocation

When a session is created SC will choose a free server and allocate it to the session. The SC uses a modified round-robin algorithm to find a free server.

Example:

When 3 server instances A1, A2, A3 have been started and each instance can serve 10 sessions named Ax-y, then the sessions will be allocated in this sequence:

A1-1, A2-1, A3-1, A1-2, A2-2, A3-2, A1-3, A2-3, A3-3, ... A1-10, A2-10, A3-10

The algorithm looks for next free server in the sequence. Because the session can be deleted in any order, holes in the sequence many emerge and the server load will be not homogenous after a time.

### 3.1.11 Message Caching

Response messages for session services sent by server to clients can be cached in SC. Clients may fetch the message from the SC cache without a server interaction. This feature may massively reduce the server load.

In order to get a message from the cache the client must provide the *cacheId* attribute in the request message like in the following example:

```
cid=CB CD SECURITY MARKET
```

If the message is not in the cache, the server receives the request and must designate the response message with the attributes *cacheId* and *cacheExpirationDateTime* like the following example:

```
cid=CB CD SECURITY MARKET  
ced=2010-08-16T20:00:00.000+0000
```

The response message is then passed to the client and also inserted into the cache. Subsequent client requests with the same *cacheId* will be satisfied without server interaction. The *cacheExpirationDateTime* controls the message expiration.

**Note:**

**While SC is building up the cache, other client requests may be rejected because the cache is temporarily invalid. The client gets the error `CACHE_LOADING` and must retry to take advantage of the cached message.**

The *cacheId* is unique per service and must be the same in the request and response message. Server response without *cacheId* or without *cacheExpirationDateTime* will clear the cached message if any.

SC looks periodically for expired messages and deletes them from the cache. The *cacheExpirationDateTime* is absolute date and time and allows using the cache in different time zones. The following picture shows the impact of the *cacheExpirationDateTime* in the messages.

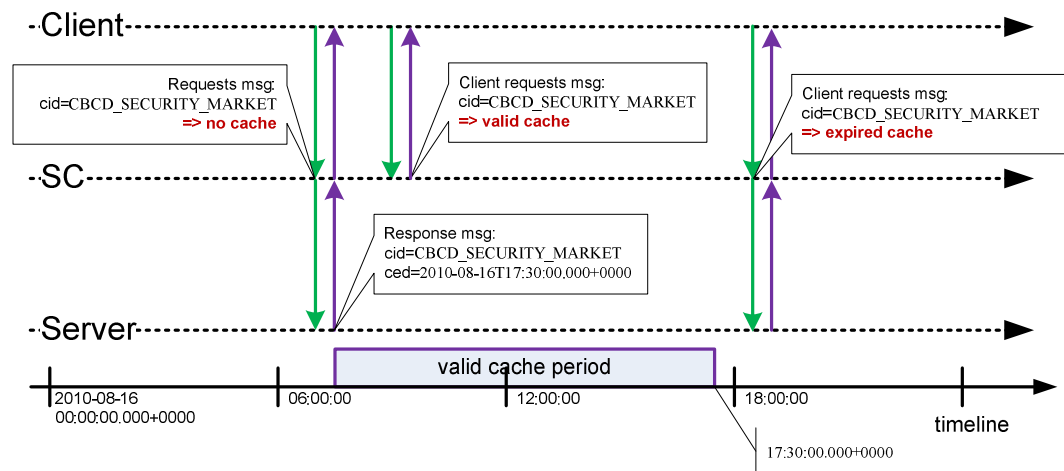

**Figure 16 Caching rules**

In order to get a message from the cache the client must designate a *cacheId*. The request message must contain the attribute like the following example:

`cid=CBCD_SECURITY_MARKET`

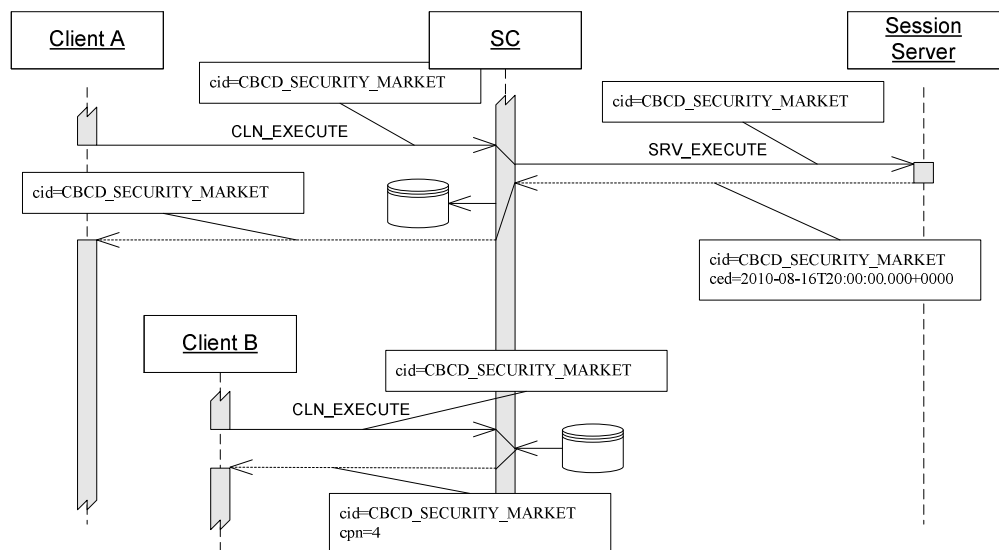

### Figure 17 Message Caching

Client and server must agree on *cacheId* which must be unique within each service. The server must send same *cacheId* in the reply as received in the request or omit it completely. Not following this rule will have negative impact on the cache performance and size.

Following actions are possible when client request is received by SC:

- No *cacheId* is in the client message => message will be passed to the server.
- cacheId* does not reference a valid message in the cache => message will be passed to the server and the cache will be potentially load the cache with its response message.
- cacheId* references a valid message in the cache => message from cache will be returned to the client. Server is bypassed.
- cacheId* references a message in the cache which is not completely loaded yet => error message `CACHE_LOADING` will be returned to the client. Server is bypassed.

Following actions are possible when server reply is received by SC:

- No *cacheId* and no *cacheExpirationDateTime* is in the message => message will not be cached and is passed to the client.
- cacheId* and *cacheExpirationDateTime* are present and *cacheExpirationDateTime* is in the past => message will not be cached and is passed to the client.
- cacheId* and *cacheExpirationDateTime* are present, *cacheExpirationDateTime* is in the future => message will be inserted into the cache and is passed to the client.
- cacheId* returned by the server does not match the *cacheId* requested by the client => message will not be cached and is passed to the client.

Caching of large messages is supported. For the transport of large cached message to the client SC uses the original parts of the message. The *cachePartNumber* is created by SC and must be returned unchanged in the client PAC request. This is how SC keeps track on parts which must be delivered next.

In cascaded SC configurations cache can be created in all SC nodes along the path from client to the server.

### 3.1.12 Message Sequencing

Message sequence number is used to identify the message during the transport. The message path from client to the server and the path from server to the client are independent and thus have independent message sequence numbers. The number is generated by the client or by the server and are passed unchanged through SC to the counterparty. SC does not validate it. ECHO messages have no message sequence numbers.

For regular operation the number is steadily increasing. This is true for the message path from client to the server. For the path from server to the client message can be fetched from cache instead of a real server reply. Such message will have its original message sequence number. The client must not validate the message sequence number in such case.

## 3.2 Publishing Services

Subscribe/Publish (server initiated communication). Publishing services allows the server to send single message to many clients through the SC.

The client sends a subscription mask to the service, and so declares its interest on certain type of a message. The application server providing the message contents must designate the message with a mask. When the message mask matches the client subscription mask, the message will be sent to the client. Multiple clients may subscribe for the same

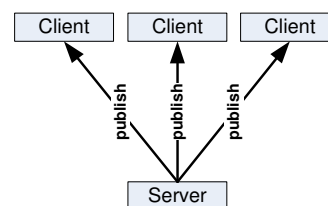

service at the same time. In such case multiple clients can get the same copy of the message. Message that does not match any client subscription is discarded.

The client must declare a notification method that is invoked when the message arrives. The client may have only one outstanding subscription per service. The message delivery must occur in guaranteed sequence. Messages from the same service will arrive in the sequence in which they have been sent.

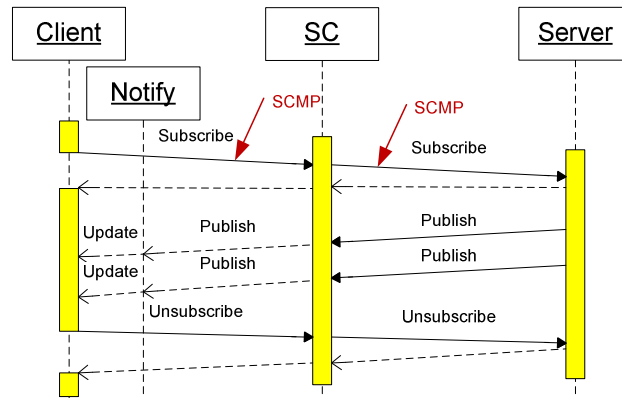
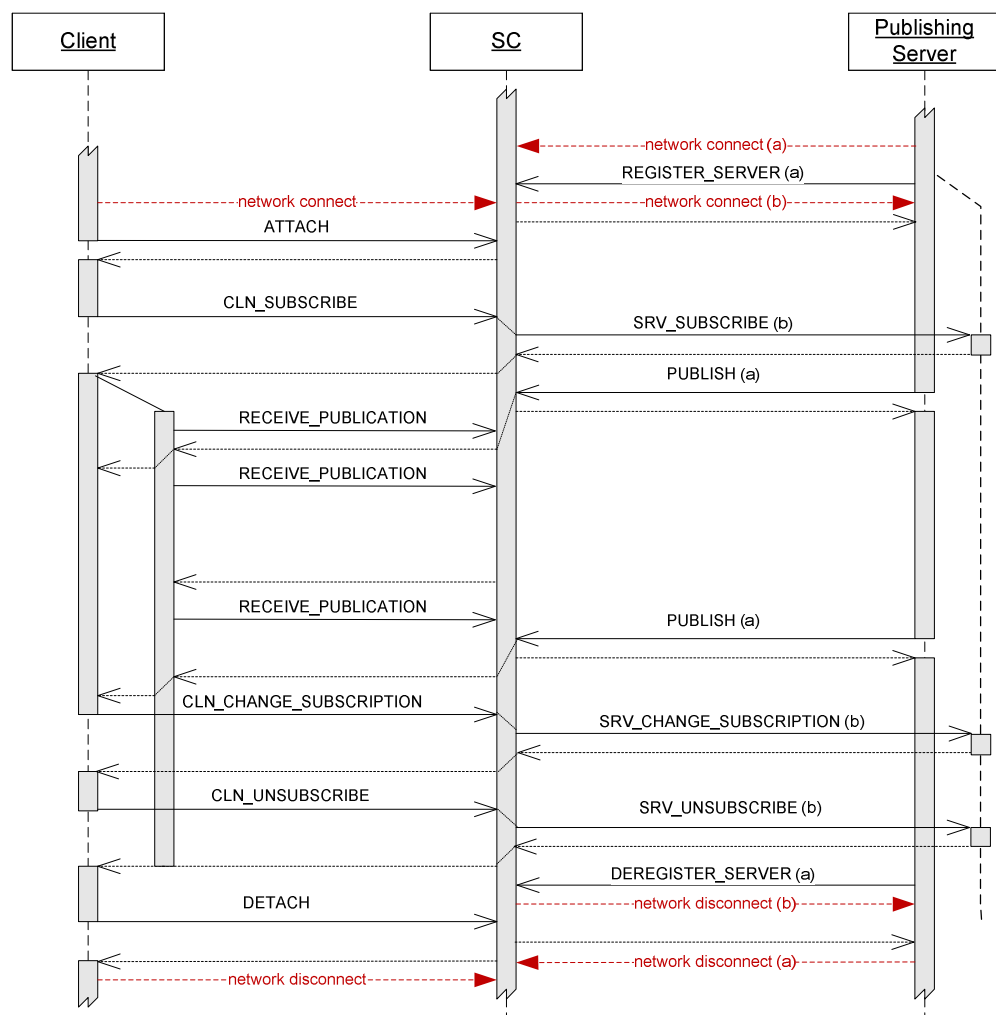

**Figure 18 Subscribe / Publish**

The client may change the subscription mask or unsubscribe. Initial subscription, subscription change or unsubscribe operation is always synchronous, even through a cascaded SCs.

Such communication style is used to get asynchronously events notifications or messages that are initiated on the server without an initial client action. It can be also used to distribute the same information to multiple clients.

The following schema shows message flow with a publishing server.



**Figure 19 Publishing Service**

*Client*

7. The client establishes a network connection to SC and starts communication with the ATTACH message. Keep-alive messages can be sent on this connection.
8. Then it subscribes to a service with the CLN\_SUBSCRIBE message and starts a listener that will receive the incoming messages.
9. The SC remembers the subscription and also creates a unique sessionId for it. It also notifies the server registered to this service with the SRV\_SUBSCRIBE message. If there is no server, the client gets an error.
10. When a message is published, SC compares the message mask with the subscription mask and based on the matching result delivers the message to the client. The client receives and processes the message and initiates the next receipt with the RECEIVE\_PUBLICATION message.
11. When no message is published within a period of time (defined by *noDataInterval*) then SC sends an empty message to the client and this initiates the next receipt with the RECEIVE\_PUBLICATION message.
12. The client can change the publication mask with the CLN\_CHANGE\_SUBSCRIPTION message or terminate the subscription with CLN\_UNSUBSCRIBE message. In both cases the server is notified with the SRV\_CHANGE\_SUBSCRIPTION or SRV\_UNSUBSCRIBE message.
13. Before the client terminates, it should send DETACH message and then terminate the network connection to SC.



When the client terminates abnormally, the SC will clear its subscription, discard all messages not delivered yet and notify the server with the SRV\_ABORT\_SESSION message. The reasons for this can be:

- Unexpected client exit
- Underlying communication error (e.g. unreachable node)

**Note**      **The client may have multiple SCs connected at the same time. Per connected SC the client may have multiple subscriptions to different services at the same time. For each subscription only one receipt request may be pending at any time.**

*Server*

1. The server establishes a network connection to SC and starts communication and registers itself as an instance of a service with the REGISTER\_SERVER message. Keep-alive messages can be sent on this connection.
2. The SC registers the server instance and will create network connection (b) back to it. Keep-alive messages will also be sent on this connection, depending on the *keepaliveInterval* set in REGISTER\_SERVER.
3. When a client subscribes or changes the subscription the server is notified with the SRV\_SUBSCRIBE or SRV\_CHANGE\_SUBSCRIPTION message. The message contains the subscription mask and additional information about the client. The server can accept or reject the subscription or its change. Like for a session service the server instance is allocated for the subscription until the subscription is deleted. The same sever instance will get all subscription actions of one client. The sessionId identifies uniquely each subscription.
4. Now the server can publish messages to the service. SC immediately responds when the PUBLISH message has been queued. The server does not wait for message delivery to the clients. The published message must have a mask designating its contents.
5. The SC compares the mask with the subscription mask of the clients and delivers the message to them. Messages that do not match any subscription are discarded. The server does not know how many clients did get the message or if any at all.
6. Messages are delivered in the order of their publishing. E.g. in order SC receives them. For this reason they are queued within SC.
7. When the client unsubscribes, the allocated server is notified with the SRV\_UNSUBSCRIBE message.
8. When the server is no longer needed it sends the message DEREGISTER\_SERVER. Then it can terminate the network connection (a) to SC.

When the client terminates abnormally, the server is notified with the SRV\_ABORT\_SESSION message.

The reasons for this can be:

- Unexpected client exit
- Underlying communication error (e.g. unreachable node)

**Note**      **The server must be active before the client will subscribe. Otherwise the client will receive an error message.**

When the server terminates timely before the client, the client will receive an error in the RECEIVE\_PUBLICATION response.

Multiple publishing servers may register to the same service. Also like a session server multiple subscriptions per server are allowed. SC chooses one server instance which is not busy when a notification must be processed. Unlike a session server the chosen server instance is allocated only for the time of the notification processing (one request).

### 3.2.1 Large Messages

Publishing of large messages works on server like sending a large response and on client like receiving a large response.

The server publishes the messages parts to the service. SC immediately responds when the PUBLISH message part has been queued. All message parts must have the same mask. The server does not wait for message delivery to the clients. The SC delivers the message parts to the subscribed clients in the right sequence like any other message. The message parts are buffered on the client until the final part arrives. Then it is passed to the application.

**Note** Publishing of large messages is not possible from multiple servers to the same service. Only one server may publish a large message to a service at the same time.

The queuing of messages in SC and buffering of message parts in the client is independent. The message flow looks as follows:

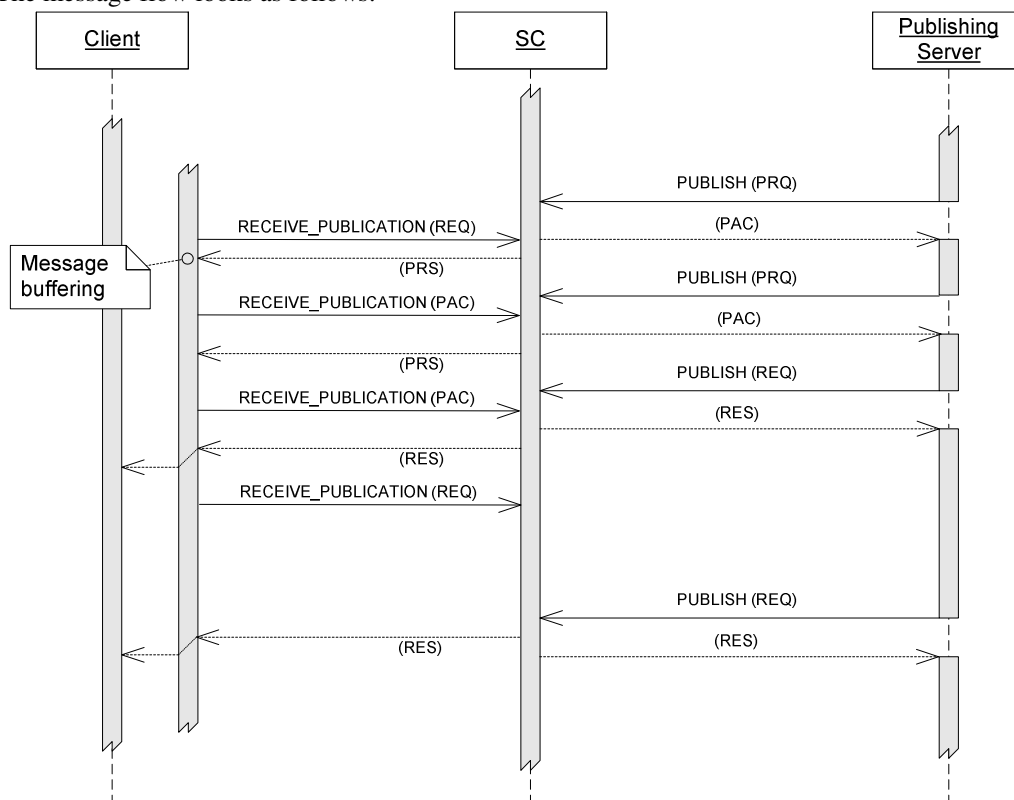

**Figure 20 Large Published Message**

### 3.2.2 Subscription Monitoring

Subscription monitoring is based on the RECEIVE\_PUBLICATION messages, exchanged periodically between the client and the SC for each active subscription. Subscription monitoring is independent on the keep-alive messages exchanged on active network connections.

The client sends RECEIVE\_PUBLICATION message in order to get the published data. The SC sends either a response message with data or an empty response with the *noData* flag when no data is available and the *noDataInterval* is exceeded. The client starts then immediately a new RECEIVE\_PUBLICATION request.

Whenever SC cleans up a subscription it sends a SRV\_UNSUBSCRIBE or SRV\_CHANGE\_SUBSCRIPTION message to the publishing server.

The SC monitors the network connection to the server, which is assumed to be reliable. When the network connection on which it registers is broken or the SC cannot send a message to the server, server is assumed to be dead and clean up will be performed.

**Note: Server exit has no an immediate impact on the client subscription! The client may still receive messages from other servers. If the server allocated to the subscription is no longer alive, the client will get error on subsequent CHANGE\_SUBSCRIPTION or UNSUBSCRIBE operations.**

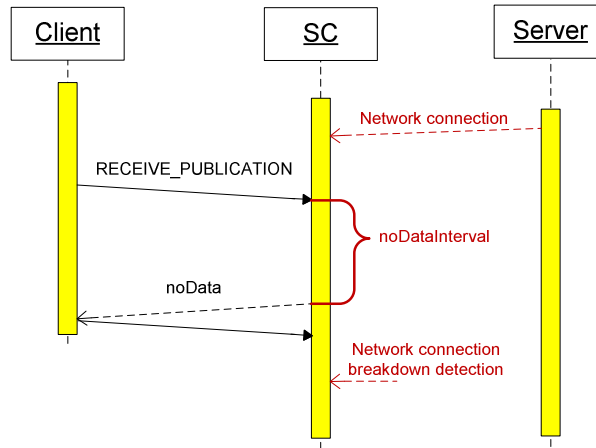

**Figure 21 Subscription Monitoring**

*Client Abort* Client subscribed to a service has always a pending RECEIVE\_PUBLICATION request. When it aborts its activity abruptly the delivery of the response message will fail and the SC will clean up its subscription.

*Server Abort* When a publishing server aborts its activity abruptly (without a neat deregister), then SC will detect the connection breakdown immediately (on the connection on which the server registers) and will clean up all its registration. The subscribed clients are informed in the next response. New server should be started immediately in order to handle incoming client subscriptions. Otherwise the subscription will fail.

*SC Abort* When SC crashes, client will detect the connection breakdown immediately, because it has a pending request. It should perform cleanup followed by a reconnect. The server will detect the connection breakdown on the connection on which it listens and should perform a cleanup followed by reconnect and service registration.

After SC restart, new subscriptions will be established. The servers must register before clients will subscribe. Otherwise the client gets an error.

### 3.2.3 Server Allocation

When a subscription is created SC will choose a free server and pass the request to it. The SC uses a modified round-robin algorithm.

Example:

When 3 server instances A1, A2, A3 have been started and each instance can serve 10 sessions named Ax-y, then the subscriptions will be allocated in this sequence:  
A1-1, A2-1, A3-1, A1-2, A2-2, A3-2, A1-3, A2-3, A3-3, ... A1-10, A2-10, A3-10

The algorithm looks for next free server in the sequence. Because the subscription can be deleted in any order, holes in the sequence many emerge and the server load will be not homogenous after a time.

### 3.2.4 Message Fan-Out

Subscription for a publishing service is kept in the SC to which the client is attached. In cascaded SC configurations this is the nearest SC node. The client subscription is combined

with subscriptions of all other clients and passed to the next SC node. I.e. the SC behaves itself like a subscribing client.

When a SC receives a published message it will pass it to all clients with matching subscription. So it does also for a cascaded SC that subscribes on behalf of its clients. In this way only one message is sent to the cascaded SC where it is distributed to all clients according to their mask. This feature massively reduced outbound network traffic to the clients.

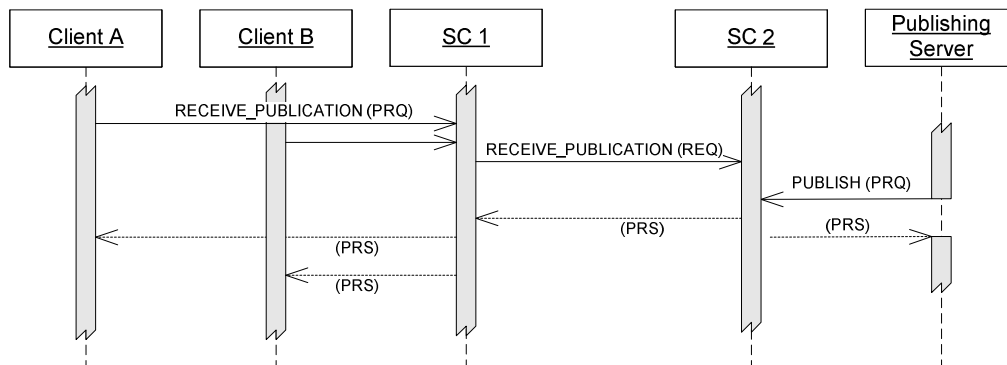

**Figure 22 Message Fan-Out**

Because the SC1 subscribes on behalf of its clients, it propagates new subscriptions or deletion of a subscription as subscription change on the SC2.

### 3.2.5 Message Sequencing

Message sequence number is used to identify the message during the transport. The message path from client to the server and the path from server to the client are independent and thus have independent message sequence numbers. The number is generated by the client or by the server and are passed unchanged through SC to the counterparty. SC does not validate it. Reply message to RECEIVE\_PUBLICATION with *nod* (no data) flag set and reply to PUBLISH message have no message sequence numbers. Regular reply message to RECEIVE\_PUBLICATION has the message sequence number created by the server and passed in PUBLISH request message.

For regular operation the number is steadily increasing. The message sequence numbers generated by the client will never reach the server. The message sequence numbered generated by the server will be passed to the client. When multiple servers are publishing messages to the same service, the message sequence number received by the client may have duplicates.

## 3.3 File Services

This SC service provides API for these file operations:

- Download file from the web server to the client.
- Upload file from the client to the web server.
- List files in a file repository on the web server.

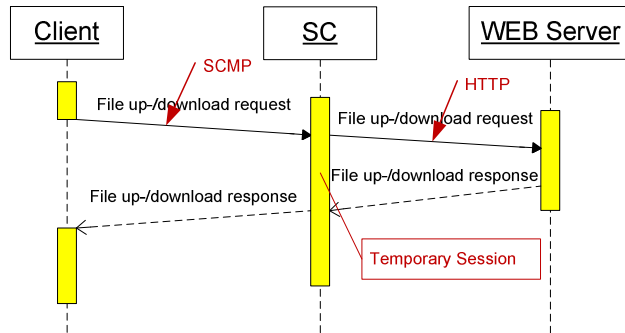

**Figure 23 File service**

This SC service provides API for these file operations:

- Download file from the web server to the client.
- Upload file from the client to the web server.
- List files in a file repository on the web server.

The client may initiate only one file operation to a service at the same time. All operations are synchronous. The SC configuration maps a service name to a directory on the web server (virtual host). The client initiates the upload or download of the file for a service. The client may upload or download file in different server locations. Directory structures (tree) are not supported. No security checks are done. The upload must be enabled and configured in the web server by installing a PHP script. This script is provided in the SC kit.

List of files is provided as an array of strings (file names). Within the message body the file list is represented as a delimited string in format:

```
{ name | }...
```

The Web Server is not registered to the service. It is configured to allow file upload, download and directory browsing for the specific directories (virtual hosts). The message flow looks as follows:

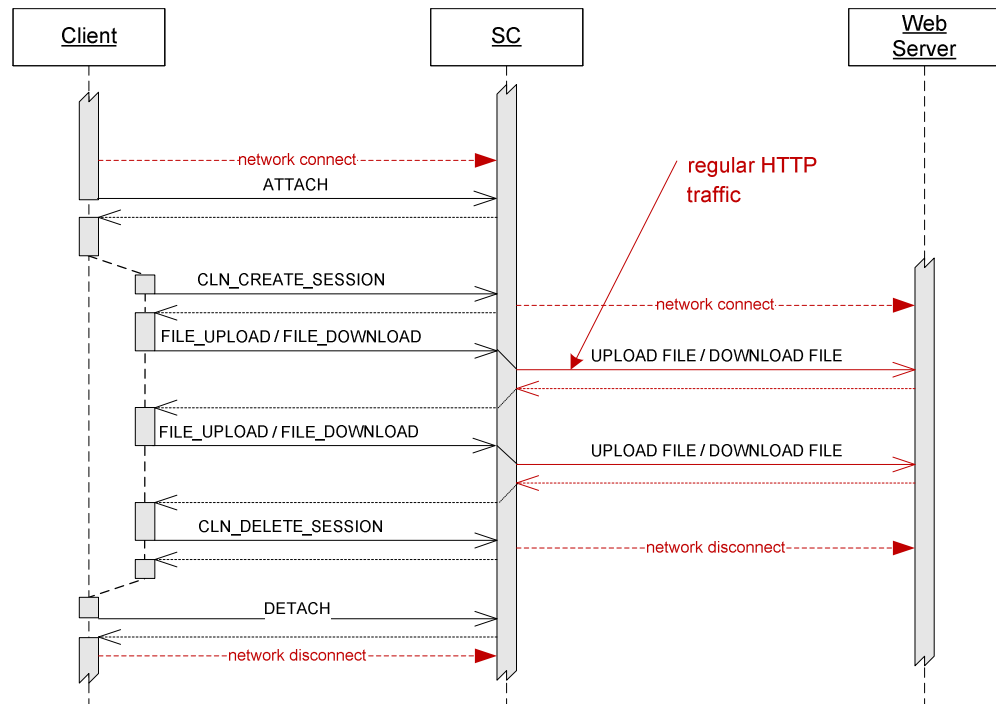

**Figure 24 File upload and download.**

The file is transferred in parts, analogically to large message. In order to keep track of the message parts and a temporary session is created. This session is automatically deleted when the file is completely uploaded or downloaded. The client API should hide the session creation and deletion. The file operation should be presented as synchronous method. On the web server the PHP script handles the message flow. It also does format the FILE\_LIST message to the appropriate format.

The network connections are dynamically created from SC to the server when they are needed. Multiple HTTP requests can be pending at the same time, each one using one network connection. Cascaded SCs on the path are transparent for the client.

### 3.4 HTTP Redirection Services

The SC supports redirecting of regular HTTP traffic to another server.

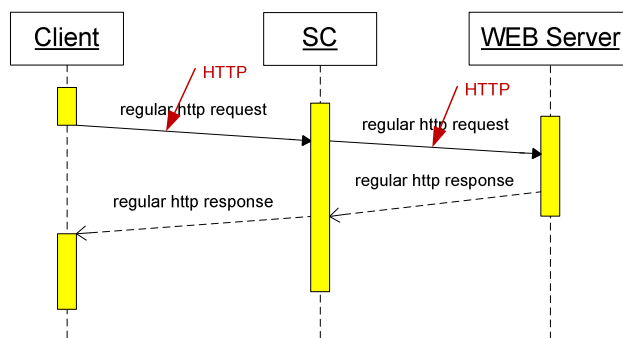

Figure 25 HTTP redirection service

HTTP traffic through the SC is possible without a service and session context. SC receives the http requests on a dedicated port and passes all HTTP traffic to the configured server. It does not act like a HTTP proxy. The requested url must be resolved (dns) by the underlying network infrastructure. SC does not provide any name resolution. The message flow looks as follows:

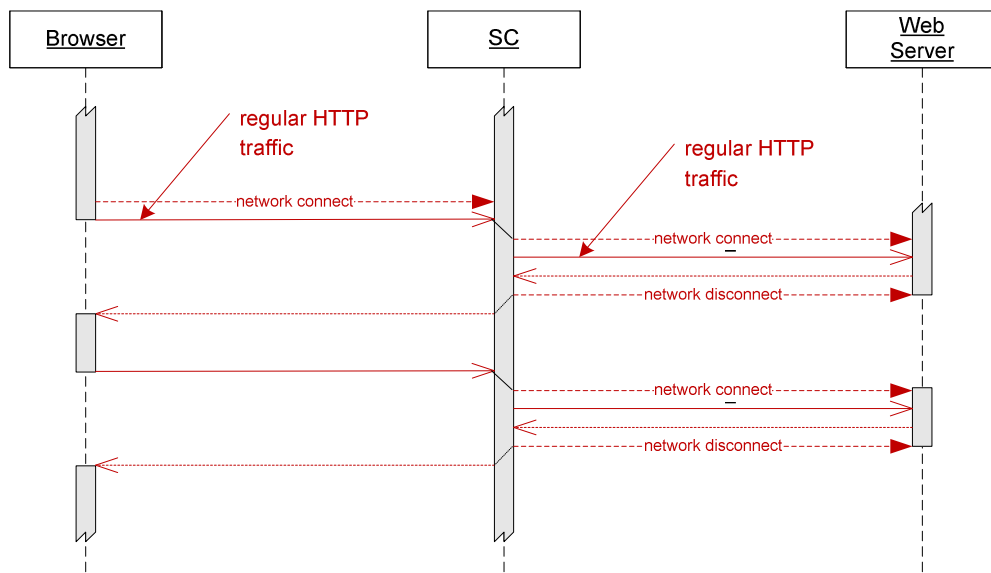

Figure 26 HTTP redirection service

The Web Server is not registered to any service. The SC configuration has one destination (host + port) for redirection of the HTTP traffic. The network connections are dynamically

created from SC to the server when they are needed. Multiple HTTP requests can be pending at the same time, each one using one network connection.

The limitation of 64kB for SCMP messages does not apply for traffic to and from Web Server.

# 4

## Cascaded Services

Cascaded Services on cascaded SCs and add security, performance and scalability to the solution built with SC. They allow distributing services on different places within the network or redirection of the communication to another location. All types of services can be configured as cascaded service. Cascaded services are fully transparent to the client and server applications.

The following rules apply:

- Cascaded service redirects message flow to service with the same name but on another host.
- Service names are unique in the entire network

### 4.1 Session Service

A cascaded session service does not hold any context information. It simply passes all traffic to the next service configured in SC1. The client session exists only on SC2 to which the server has registered. Server cannot register to a cascaded service.

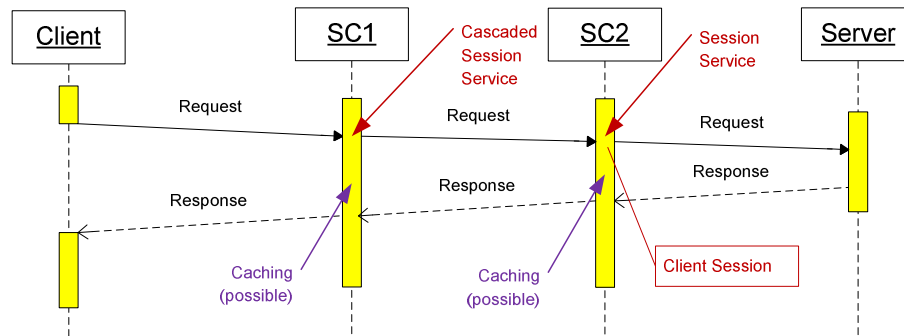

Figure 27 Cascaded Session Service (simplified)

Caching can be enabled on both SCs. This allows caching of data closer to the consumer.

### 4.2 Publishing Service

A cascaded publishing service behaves like a regular publishing service, but combines multiple client subscriptions and subscribes with a combined subscription on SC2. In this way it receives all messages only once and distributes them to the subscribed clients. This behaviour is called fan-out. Server cannot publish to a cascaded service. The client subscription is kept on SC1. The combined subscription is kept on SC2. The client subscription, change subscription and unsubscribe are passed to the server in their original form. Combined subscriptions are not passed to the server at all.

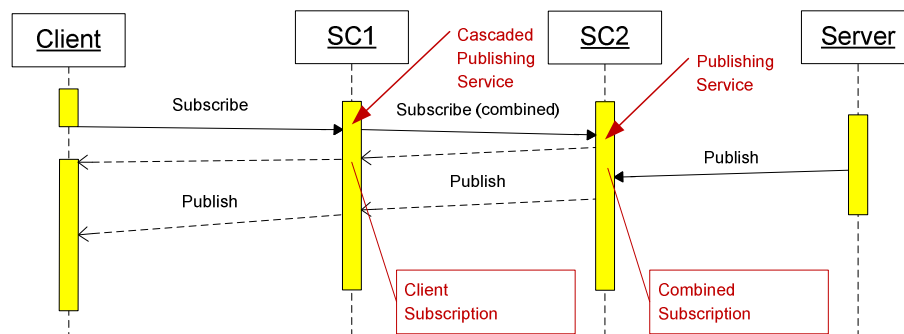

Figure 28 Cascaded Publishing Service (simplified)



### 4.3 File Service

A cascaded file service does not hold any context information. It simply passes all traffic to the next service configured in SC1.

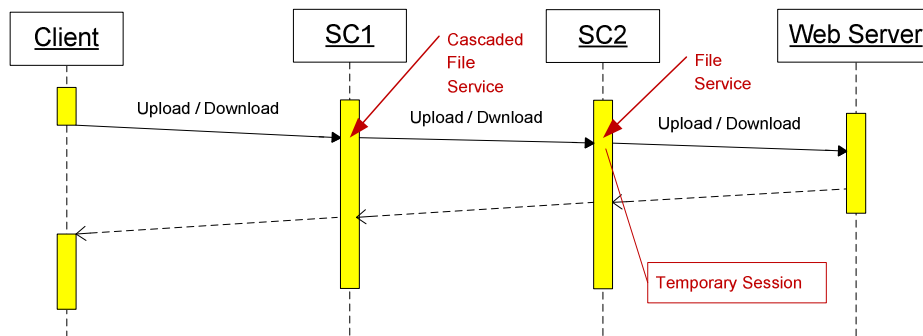

Figure 29 Cascaded File Service

### 4.4 Cascaded HTTP Redirection Service

HTTP cascaded service is simple redirection and thus passes all http traffic to the next configured host. The SC1 configuration has one destination (host + port) for redirection of the HTTP traffic. The configuration is similar to SC2 where the destination is the Web Server.

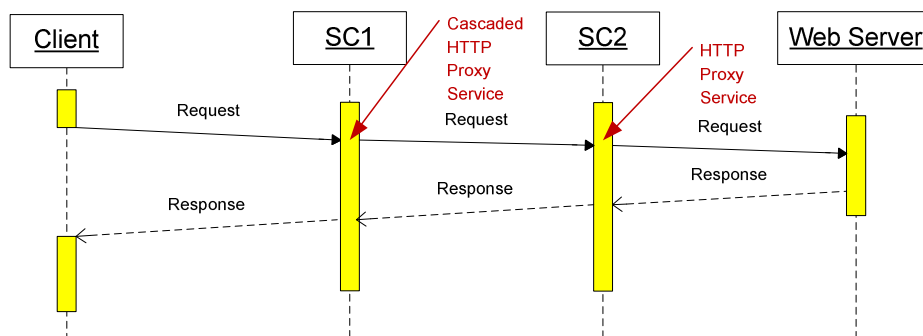
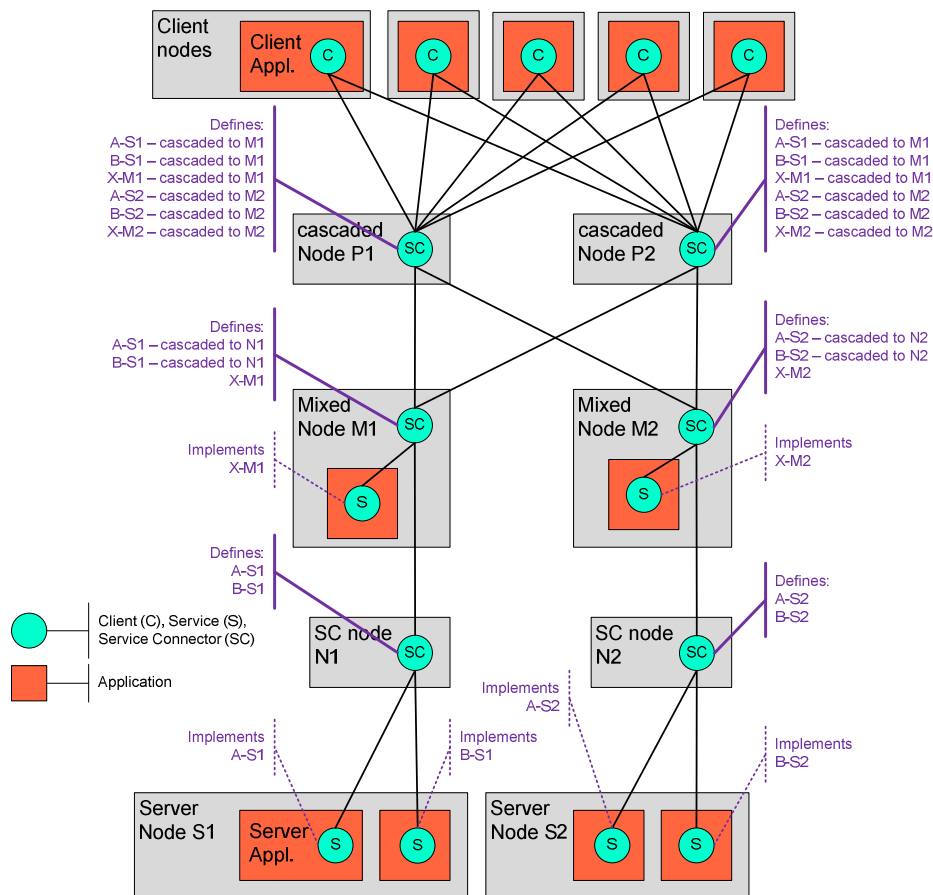

Figure 30 Cascaded HTTP Redirection Service

### 4.5 Service Routing

Cascaded SC configurations allow service routing. Service routing is fully transparent to the client and server applications. All service names must be unique through the entire network topology. Redirecting service to another service is not supported.



**Figure 31 Service Routing**

The schema above shows a network with fully redundant services located in four locations:

The clients may access only the nodes P1 and P2 placed potentially in DMZ. When one of them is unavailable the other may be used. All services are cascaded. These nodes may be omitted when the client is allowed to connect directly to nodes M1 and M2

Nodes M1 and M2 implement the local service X and cascade all other services. If one of the nodes is unavailable, the client may still use the other one.

Nodes N1 and N2 show SC placed on an extra node. They may be omitted is SC is placed on node S1 and S2. Services A and B are local.

Nodes S1 and S2 implement the local service A and B.

Additionally the server application may register itself on different SCs. This is not shown here. It would additionally increase the service accessibility, but would require cross connection between the nodes.

## 5

## State Diagrams

The following chapter shows state diagrams for the client and the server.

### 5.1 Client

#### Session Service

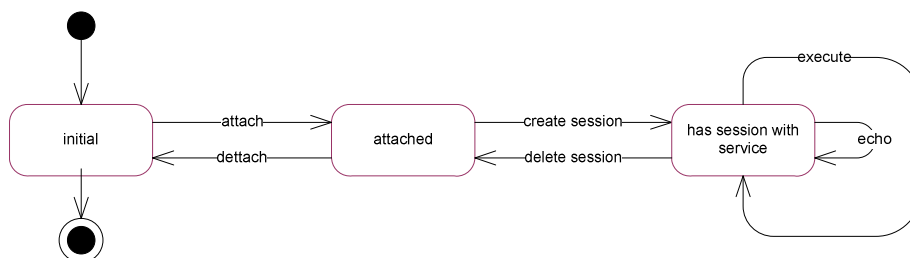

**Figure 32 Client states for session service**

Message exchange is only possible within a session. File services are available in attached state. On error the following state is established:

- Error in ATTACH results in *initial* state.
- Error in DETACH results in *initial* state.
- Error in CLN\_CREATE\_SESSION results in *attached* state.
- Error in CLN\_DELETE\_SESSION results in *attached* state.
- Error in CLN\_EXECUTE results in *has session with service* state. Except in case the message contains sessionId which is no longer valid.
- Error in ECHO results in *attached* state. The session is deleted.

Client getting error on CLN\_EXECUTE should issue CLN\_DELETE\_SESSION and ignore all errors.

#### Publishing Service

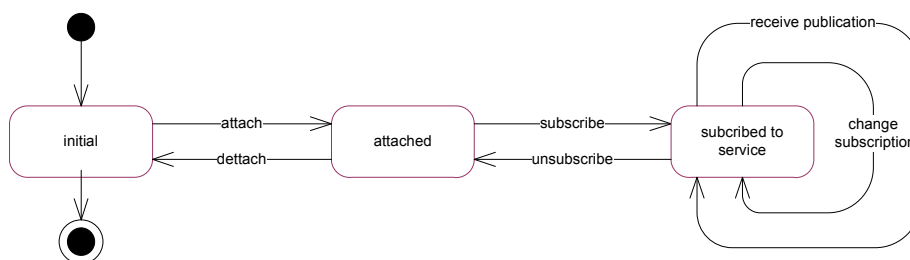

**Figure 33 Client states for publishing service**

On error the following state is established:

- Error in ATTACH results in *initial* state.
- Error in DETACH results in *initial* state.
- Error in CLN\_SUBSCRIBE results in *attached* state.
- Error in CLN\_UNSUBSCRIBE results in *attached* state.
- Error in CLN\_CHANGE\_PUBLICATION results in *subscribed to service* state. Except in case the message contains sessionId which is no longer valid.
- Error in RECEIVE\_PUBLICATION results in *subscribed to service* state.

Client getting error on RECEIVE\_PUBLICATION should issue CLN\_UNSUBSCRIBE and ignore all errors.

## 5.2 Server

### Session Service

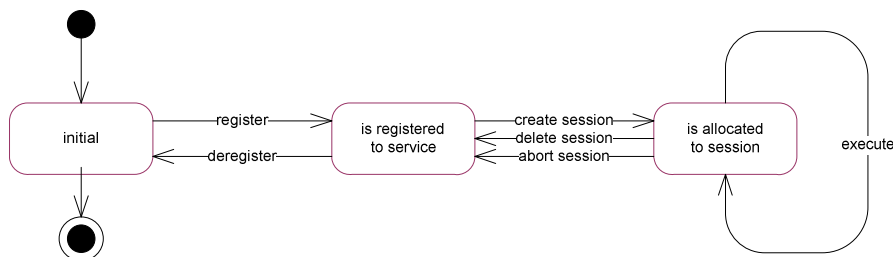
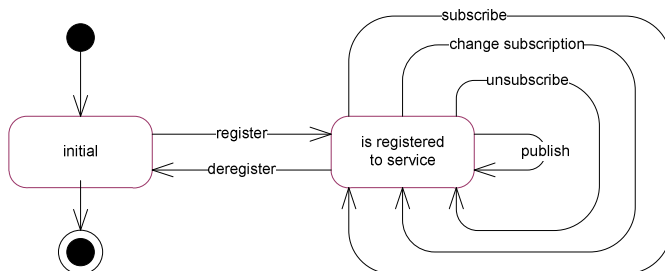

**Figure 34 Server states for session service**

The de-allocation of the server may happen either due to a regular client action (delete session) or die to an error handled by SC (abort session). On error the following state is established:

- Error in REGISTER\_SERVER results in *initial* state.
- Error in DEREGISTER\_SERVER results in *initial* state.
- Error in SRV\_CREATE\_SESSION results in *is registered to service* state.
- Error in SRV\_DELETE\_SESSION results in *is registered to service* state.
- Error in SRV\_ABORT\_SESSION results in *is registered to service* state.
- Error in SRV\_EXECUTE results in *is allocated to session* state.

### Publishing Service



**Figure 35 Server states with publishing service**

Publishing server gets short requests to verify the subscribing client when it subscribes, unsubscribes or changes its subscription. No durable session is created. On error the following state is established:

- Error in REGISTER\_SERVER results in *initial* state.
- Error in DEREGISTER\_SERVER results in *initial* state.
- Error in SRV\_SUBSCRIBE results in *is registered to service* state.
- Error in SRV\_CHANGE\_PUBLICATION results in *is registered to service* state.
- Error in SRV\_UNSUBSCRIBE results in *registered to service* state.
- Error in PUBLISH results in *is registered to service* state.

## 6

# Relationship Diagram

The following chapter explains the relationship between the SC entities.

### 6.1 Client

Client may have one or more concurrent connections to SC instances. For one SC connection client may have one or more concurrent sessions or subscriptions to services. Multiple sessions or subscriptions to the same service are possible.

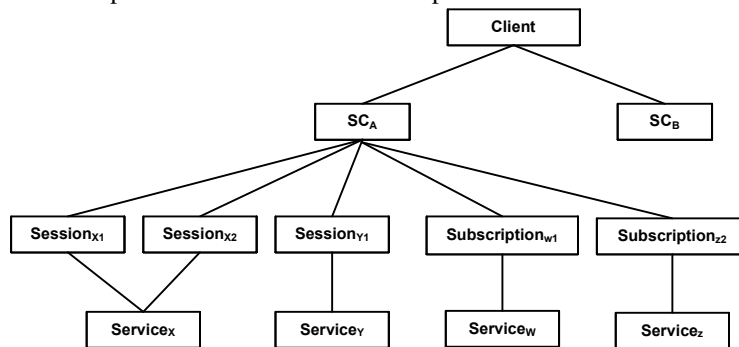

Figure 36 Client relationships

### 6.2 Server

#### Single Session Server

Single session server may have only one concurrent connection to a SC. It may register for only one service and only one session.

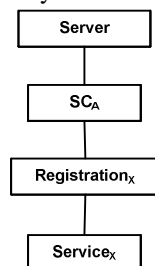

Figure 37 Single Session Server relationships

#### Multi Session Server

Multi session server may have multiple concurrent connections to SC instances. Within one connection it may register to serve multiple sessions of the same service. When it will serve multiple services, it can use the same connection to SC.

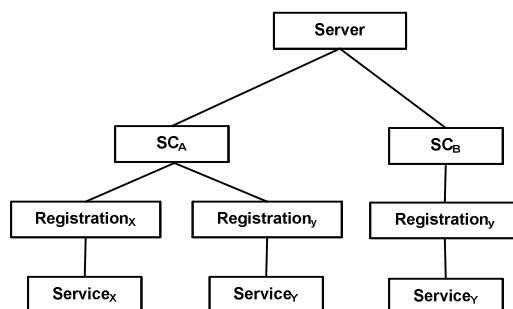
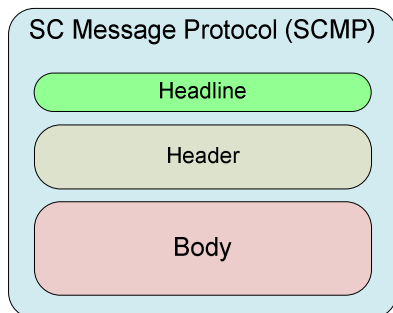

Figure 38 Multi Session Server relationships

# 7

# Message Structure

The Service Connector Message Protocol (SCMP) uses a simple header – body structure.



**Figure 39 Message Structure**

Message example as visible with Wireshark:

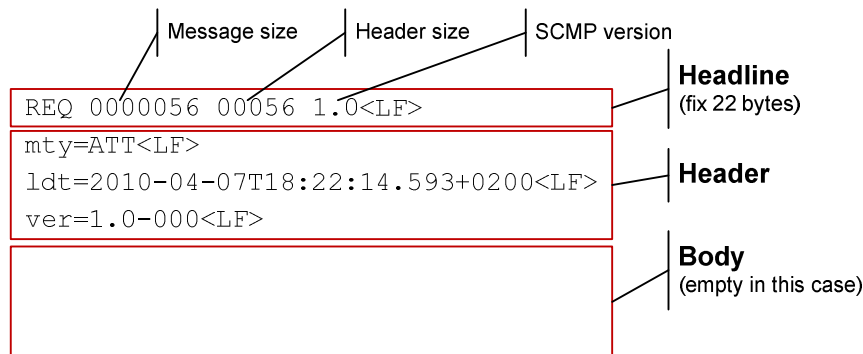

**Figure 40 Message Structure Example**

## 7.1 Headline

The fix size (22 bytes) headline defines the header key, the total size of the message, size of the header and the SCMP version. It is encoded in ISO-8859-1 (Latin 1) and terminated by <LF>.

### HeaderKey

The header key defines the purpose of the message and can be:

- REQ – Request from client or server to SC or request from SC to server
- RES – Response from server to SC or SC to client or to server
- PRQ – Large request part from client or server
- PRS – Large response part from server to client
- PAC – Part acknowledge, request to get more parts
- KRQ – Keep-alive request
- KRS – Keep-alive response
- EXC – Exception returned after REQ, PRQ or KRQ in case of an error

### Message size

The complete size of the message in bytes counted from the beginning of the header until the end of the message body. The number is 7 bytes long and has leading zeros. (The maximal allowed message size on OpenVMS platform is 64kB. On other platforms the limit is 9'999'999 bytes.)

### Header Size

The size of the message header in bytes counted from the beginning of the header until the end of the message header. The number is 5 bytes long and has leading zeros.

## Version

The SCMP version is the version of the **protocol specification** to which this message adheres. It has fixed format 9.9 and it ensures that the receiver knows how this message is structured. The version number (e.g. 2.5) means: 2 = Release number, 5 = Version number.

The receiver may implement multiple protocol versions, thus “understand” older versions. The following matching rule applies:

- Message: 2.5 + receiver implements: 2.5 => compatible
- Message: 2.5 + receiver implements: 2.6 => compatible
- Message: 2.7 + receiver implements: 2.5 => not compatible (message may have new headers unknown to the receiver)
- Message: 1.4 + receiver implements: 2.5 => not compatible (old message structure and possibly not understood here)
- Message: 2.5+ + receiver implements: 1.8 => not compatible (new message structure and surely not understood here)

Handling of the SCMP Version in a network hierarchy works according to the following rules and restrictions. The components supporting a SCMP Version have to follow the top down restrictions. This means the requester is able to connect to components supporting equal or higher protocol version. In other words server and SC on level zero have to support equal or higher SCMP Version than connecting clients. Clients and Proxies may connect using older versions.

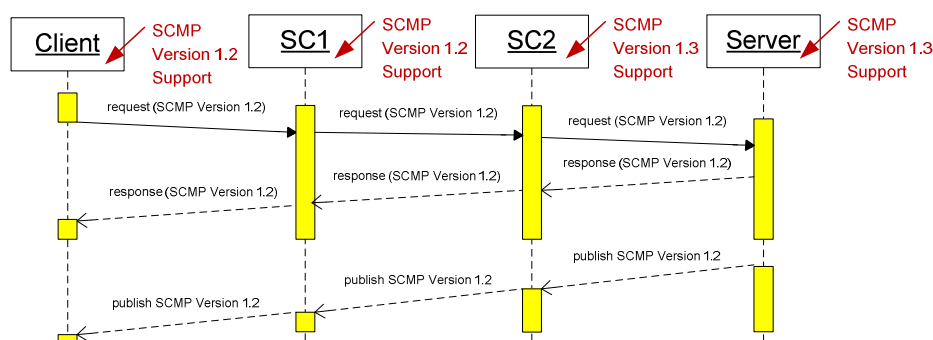

**Figure 41 SCMP Version concept**

In the context of a session service request the server has to respond with protocol version given in the request. Protocol version is received from the client and nowhere changes for the whole communication flow.

In the context of a publish service the server has to publish messages with protocol version compatible to the clients version (lowest version in field). For example the server supports SCMP Version 1.3 and connected clients version 1.2 the server has to publish with version 1.2. Otherwise clients are not able to receive messages.

Fault messages from the SC to the server may have version 1.2 even if SC and Server support 1.3. This happens because supported protocol version number of the server is unknown for the SC.

In conclusion components supporting an SCMP Version have to implement the matching rules and version logic properly in any case.

## 7.2 Header

Message header has variable length and contains attributes of variable number and length. Each attribute is on a separate line e.g. delimited by <LF>. Attributes and values are encoded in ISO-8859-1 (Latin 1) character set.

### Note:

“=” or <LF> characters are not allowed within attribute names and/or values.

Example:

```
mty=ATT
ver=1.0-000
kpt=10
ldt=2010-04-07T18:22:14.593+0200
```

Unknown header attributes will be ignored and **not** forwarded. The sequence order of the attributes is meaningless.

### 7.3 Body

The message body has variable length and contains binary data or ISO-8859-1 (Latin 1) encoded text. The attribute *bodyType* defines the format. It is under control of the applications. When compression is enabled, body is ZIP-compressed during transmission.

SC uses ZIP compression described in:

<http://www.pkware.com/documents/casestudies/APPNOTE.TXT>

and documented in:

<http://download.oracle.com/javase/1.4.2/docs/api/java/util/zip/Deflater.html>

### 7.4 SCMP over TCP/IP

For direct transport over TCP/IP the headline, messages header and the body is directly written to the network connection.

### 7.5 SCMP over HTTP

For transport over HTTP the headline and messages header have content type **text/plain** and the message body is multipart, the content type **application/octet-stream**.

The request uses method POST to send the request. The response is regular HTTP response.

In order to distinguish regular (plain) HTTP traffic from SCMP over HTTP, the following HTTP headers are used for request and response:

```
Pragma: SCMP
Cache-Control: no-cache
```

Actually chunked transfer encoding and pipelining are not used.

Wireshark example:

```
POST / HTTP/1.1
Content-Length: 178
Content-Type: text/plain
Host: 192.234.123.33
User-Agent:1.6.0_07
Accept:text/html, image/gif, image/jpeg, *; q=.2, */*; q=.2
Connection:keep-alive
Cache-Control: no-cache
```

```
REQ 0000056 00056 1.3
mty=ATT
ver=1.0-000
ldt=2010-04-07T18:22:14.593+0200
```

```
HTTP/1.1 200 OK
Content-Length: 74
Content-Type: text/plain
Cache-Control: no-cache
```

```
RES 0000041 00041 1.3
mty=ATT
```



ldt=2010-04-07T18:22:14.593+0200

## 8

## SCMP Messages

Server may play the role of a client and consume other services. In such configuration message which belong to the client and to the server must have different types. For this reason messages initiated by the client have CLN\_ prefix and messages sent to the server the SRV\_ prefix.

### 8.1 Keep-alive

Keep-alive messages are sent in regular intervals on all idle connections initiated by a network peer (client, server or SC). The only purpose of keep-alive messages is to preserve the connection state in the firewall placed between the communicating peers and resets its internal timeout. See also Chapter 2.3

Using of keep-alive messages can be disabled with the *keepaliveInterval (kpi)* attribute. The message has only a headline and no attributes and no body. The format is:

```
KRQ 0000000 00000 1.3
```

for request and

```
KRS 0000000 00000 1.3
```

for response.

### 8.2 ATTACH (ATT)

This message is sent from the client to SC in order to initiate the communication. The message has no body and contains these attributes:

```
mty=ATT  
ver=1.0-023  
ldt=1997-07-16T19:20:30.064+0100
```

SC receives the message and sends back the response:

```
mty=ATT  
ldt=1997-07-16T19:20:34.044+0200
```

When an SC error occurs the response message contains the attributes:

```
mty=ATT  
ldt=1997-07-16T19:20:30.453+0100  
sec=3000  
set=SCMP version mismatch (Received=1.0-23, Required 1.1.-34)
```

Actually this message is only used to check the availability of the SC and to check the compatibility of the communicating partners.

### 8.3 DETACH (DET)

This message is sent from the client to SC in order to terminate the communication. The message has no body and contains these attributes:

```
mty=DET
```

SC receives the message and sends back the response:

```
mty=DET
```

## 8.4 INSPECT (INS)

This message is sent from the client to SC in order to get internal information from the SC. The message has body of type *text* and contains these attributes:

mty=INS  
bty=txt  
ipl=10.0.4.32

The message returned by SC has a body of type *text* and contains these attributes:

mty=INS  
bty=txt  
ipl=10.0.4.32

The request and response message body has the format according to the following table:

| <b>Request format</b>                                     | <b>Response format</b>   | <b>Comment</b>  |
|---|--|---|
| state?serviceName= <i>regexName</i>                       | name=state {&name=state}...  | Returns state values <i>enabled</i> or <i>disabled</i> for services matching the <i>regexName</i> .   |
| sessions?serviceName= <i>regexName</i>                    | name=9999/9999 {&name=9999/9999}...  | Returns <i>allocated</i> / <i>available</i> count of sessions for services matching the <i>regexName</i> .  |
| inspectCache?serviceName= <i>name</i> &cacheId= <i>id</i> | return= <i>success</i> &cacheId= <i>id</i> &cacheState= <i>state</i> &cacheSize=9999&cacheExpiration= <i>datetime</i><br>return= <i>notfound</i> | Returns information about the given <i>Id</i> in cache. Returns <i>notfound</i> if cacheId does not exist.  |
| scVersion   | <i>scVersion</i>   | Returns the version of the SC the client communicates to.   |
| serviceConfiguration?serviceName= <i>name</i>             | serviceType= <i>serviceType</i>  | Returns the serviceType of given service name. Service types in SC: SESSION_SERVICE, PUBLISH_SERVICE, CASCADED_SESSION_SERVICE, CASCADED_PUBLISH_SERVICE, CASCADED_FILE_SERVICE, FILE_SERVICE |

When an SC error occurs the response message contains no body and the attributes:

mty=INS  
sec=370  
set=Unkown service: P01\_RTXS\_RPRWS3

## 8.5 MANAGE (MGT)

This message is sent from the client to SC in order to change the SC behaviour. The message has body of type *text* and has these attributes:

mty=MGT  
bty=txt  
ipl=10.0.4.32

The request message body has the format according to the following table:

| <b>Request format</b>                 | <b>Comment</b>   |
|---------------------------------------|--|
| disable?serviceName= <i>regexName</i> | Disables the services matching the <i>regexName</i> . When service is disabled, clients cannot create new sessions or subscriptions. Existing sessions or subscriptions are not affected. The initial (default) state of the service is defined in the SC configuration. |
| enable?serviceName= <i>regexName</i>  | Enables the services matching the <i>regexName</i> .   |
| clearCache                            | Clears the message cache or all services   |
| dump                                  | Dumps internal SC structures into a snapshot file (xml structure). This can be used for troubleshooting  |

|      |   |
|------|---|
| kill | Terminates the SC. The will immediately exit without any cleanup action.<br><b><u>The SC will execute this request only if the IP address in ipl is equal to the IP address of the local node.</u></b> This prevents shutdown issued from remote nodes. |
|------|---|

The message returned by SC has no body and contains these attribute:

mty=MGT  
ipl=10.0.4.32

When an SC error occurs the response message contains no body and the attributes:

mty=MGT  
sec=370  
set=Unkown service: P01\_RTXS\_RPRWS3

## 8.6 CLN\_CREATE\_SESSION (CCS)

This message is sent from the client to SC in order to create a new session for a service. The message has optional a body and contains these attributes (as seen by the SC):

mty=CCS  
msn=1  
nam=P01\_RTXS\_RPRWS1  
ipl=10.0.4.32/10.0.4.32  
sin=SNBZHP - TradingClientGUI 10.2.7  
eci=300  
oti=10000

SC receives the message and does these actions:

1. Generates a unique session id
2. Chooses a free server instance from the list of available servers serving the requested service.
3. Allocates the server instance to this session
4. Sends the message SRV\_CREATE\_SESSION to the allocated server and awaits the server response.
5. If the response message does not contain the attribute rejectFlag, the SC keeps the session and sends back to client the message with optional body and the following attributes:

mty=CCS  
msn=1  
nam=P01\_RTXS\_RPRWS1  
sin=server-version:V2.1-453  
sid=cdc50b36-1fc4-4f9e-8430-d2e3d7284d9d

6. If the response message contains the attribute rejectFlag, the SC deletes the session, de-allocates the server and sends back to client the message with optional body and the following attributes:

mty=CCS  
msn=1  
nam=P01\_RTXS\_RPRWS1  
sin=server-version:V2.1-453  
rej  
aec=4334591  
aet=%RTXS-E-NOPARTICIPANT, Authorization error – Unknown participant

When an SC error occurs the response message contains the attributes:

mty=CCS  
sec=330  
set=Unkown service: P01\_RTXS\_RPRWS3

If SC cannot allocate a free server instance for the session it will respond with the error set=No free server available for service: P01\_RTXS\_RPRWS3.

Large messages are not supported in this context.

## 8.7 CSC\_CREATE\_SESSION (XCS)

This message is sent from the cascaded SC to another SC order to process the client create session request. The message has optional a body and contains these attributes (as seen by the receiving SC):

```
mty=XCS
ver=1.0-023
msn=1
nam=P01_RTXS_RPRWS1
ipl=10.0.4.32/10.0.4.32
sin=SNBZHP - TradingClientGUI 10.2.7
eci=300
oti=10000
```

SC receives the message, checks the passed version number and processes this like a CLN\_CREATE\_SESSION message.

When an SC error occurs the response message contains the attributes:

```
mty=XCS
sec=330
set=Unkown service: P01_RTXS_RPRWS3
```

If SC cannot allocate a free server instance for the session it will respond with the error set=No free server available for service: P01\_RTXS\_RPRWS3.

Large messages are not supported in this context.

## 8.8 SRV\_CREATE\_SESSION (SCS)

This message is sent from the SC to the server when a server instance has been be allocated to a session. Optionally the message has a body and contains these attributes:

```
mty=SCS
msn=1
nam=P01_RTXS_RPRWS1
sid=cdc50b36-1fc4-4f9e-8430-d2e3d7284d9d
sin=SNBZHP - TradingClientGUI 10.2.7
ipl=10.0.4.32/10.0.4.32/10.2.54.12
oti=10000
```

The server receives the message and must decide to accept or reject this request. If it accepts, then the reply has an optional body and the following attributes:

```
mty=SCS
msn=1
nam=P01_RTXS_RPRWS1
sin=server-version:V2.1-453
sid=cdc50b36-1fc4-4f9e-8430-d2e3d7284d9d
```

If it rejects the session, then the reply has an optional body and the following attributes:

```
mty=SCS
msn=1
nam=P01_RTXS_RPRWS1
sin=server-version:V2.1-453
sid=cdc50b36-1fc4-4f9e-8430-d2e3d7284d9d
```

```
rej
aec=4334591
aet=%RTXS-E-NOPARTICIPANT, Authorization error – Unknown participant
```

The *aec* / *aet* attributes should contain readable information describing the rejection reason.

## 8.9 CLN\_DELETE\_SESSION (CDS)

This message CLN\_DELETE\_SESSION is sent from the client to SC in order to terminate an existing session. The message has no body and contains these attributes:

```
mty=CDS
msn=974834
nam=P01_RTXS_RPRWS1
sid=cdc50b36-1fc4-4f9e-8430-d2e3d7284d9d
sin=rollback
oti=10000
```

SC receives the message and does these actions:

1. Finds the server allocated to this session
2. Sends the message SRV\_DELETE\_SESSION to the allocated sever and awaits its response.
3. De-allocates the server instance from this session
4. Sends back the message CLN\_DELETE\_SESSION with the following attributes:

```
mty=CSD
msn=974834
nam=P01_RTXS_RPRWS1
sid=cdc50b36-1fc4-4f9e-8430-d2e3d7284d9d
```

Due to timing issues the client may send a delete session request to a non existing session or to session that has no allocated server. The SC handles such situations and responds with a appropriate error message.

When an SC error occurs the response message contains the attributes:

```
mty=CDS
sec=330
set=Session does not exist
```

## 8.10 CSC\_DELETE\_SESSION (XDS)

This message is sent from the cascaded SC to another SC order to process the client delete session request. The message has no body and contains these attributes:

```
mty=XDS
msn=974834
nam=P01_RTXS_RPRWS1
sid=cdc50b36-1fc4-4f9e-8430-d2e3d7284d9d
sin=rollback
oti=10000
```

SC receives the message and process it like a CLN\_DELETE\_SESSION message. When an SC error occurs the response message contains the attributes:

```
mty=XDS
sec=330
set=Session does not exist
```

## 8.11 SRV\_DELETE\_SESSION (SDS)

This message is sent from the SC to the server when the session will be deleted by the client and the server instance will no longer be bound to it. The message has no body and contains these attributes:

```
mty=SDS
msn=974834
nam=P01_RTXS_RPRWS1
sid=cdc50b36-1fc4-4f9e-8430-d2e3d7284d9d
sin=rollback
oti=10000
```

The server must return a message with the following attributes:

```
mty=SDS
msn=974834
nam=P01_RTXS_RPRWS1
sid=cdc50b36-1fc4-4f9e-8430-d2e3d7284d9d
```

In case the server does not respond within the given operation timeout (oti) the SC will abort the session, deregister the server and close all connections to the server.

After this message the server will not receive any data requests until the next session is started.

## 8.12 SRV\_ABORT\_SESSION (SAS)

This message is sent from the SC to the server when the session is aborted due to errors or other unexpected event. The message has no body and contains these attributes:

```
mty=SAS
nam=P01_RTXS_RPRWS1
sid=cdc50b36-1fc4-4f9e-8430-d2e3d7284d9d
sec=302
set=Session timeout exceeded
oti=2000
```

The server must return a message with the following attributes:

```
mty=SAS
nam=P01_RTXS_RPRWS1
sid=cdc50b36-1fc4-4f9e-8430-d2e3d7284d9d
```

In case the server does not respond within the configured operation timeout (oti) the SC will abort the session, deregister the server and close all connections to the server.

After this message the server will not receive any data requests until the next session is started.

## 8.13 REGISTER\_SERVER (REG)

This message is sent from the server instance to SC in order to tell the SC which service it serves. From this time SC starts monitoring the arrival of CHECK\_REGISTRATION message and will clean-up the server if it does not arrive timely. The message has no body and contains these attributes:

```
mty=REG
nam=P01_RTXS_RPRWS1
mxs=10
mxc=5
imc
pnr=9100
ver=1.0-023
ldt=1997-07-16T19:20:30.064+0100
```

kpi=360  
cri=360

SC receives the message and performs these actions:

1. Registers the server for this service.
2. Creates the requested number of connection to the server on port that was specified.
3. Starts monitoring the connection based on keep alive interval value
4. Sends back a message with the following attributes:  
mty=REG  
nam=P01\_RTXS\_RPRWS1  
ldt=1997-07-16T19:20:30.064+0100

When an SC error occurs the response message contains the attributes:

mty=REG  
sec=330  
set=Service name=P01\_RTXS\_RPRWS5 not found

## 8.14 CHECK\_REGISTRATION (CRG)

This message is sent in periodic intervals from the registered server to SC in order to check its registration. The SC is checking the arrival of this message and will clean-up the server if the message will not arrive timely. The interval in which this message is sent is defined by the *checkRegistrationInterval* defined in REGISTER\_SERVER message. In order to compensate the network latency the interval in SC is multiplied by *checkRegistrationIntervalMultiplier* = (default= 1.2). If the *checkRegistrationInterval* = 0 then SC will not monitor the interval and this message can be sent irregularly. The message has no body and contains these attributes:

mty=CRG  
nam=P01\_RTXS\_RPRWS1

SC receives the message checks the registration and sends back message with the following attributes:

mty=CRG  
nam=P01\_RTXS\_RPRWS1

When an SC error occurs the response message contains the attributes:

mty=CRG  
sec=330  
set=Server is not registered

## 8.15 DEREGISTER\_SERVER (DRG)

This message is sent from the server instance to SC in order to tell the SC that the server will no longer provide the service. The message has no body and contains these attributes:

mty=DRG  
nam=P01\_RTXS\_RPRWS1

SC receives the message and does these actions:

1. Finds the server and performs a cleanup by aborting and de-allocation all sessions of this server. If the server has allocated sessions the SC will first send the SRV\_ABORT\_SESSION to it.
2. Terminates all connections that have been established from SC to this server.
3. Sends back message with the following attributes:  
mty=DRG  
nam=P01\_RTXS\_RPRWS1

When an SC error occurs the response message contains the attributes:

mty=DRG



```
sec=330  
set=Server is not registered
```

After this message the server may disconnect from the SC.

## 8.16 CLN\_EXECUTE (CXE)

This message is sent from the client to SC in order exchange information with the allocated server. The client may send this message only in scope of a session. The message has a body and contains these attributes:

```
mty=CXE  
nam=P01_RTXS_RPRWS1  
sid=cdc50b36-1fc4-4f9e-8430-d2e3d7284d9d  
msn=974833  
min=SECURITY_MARKET_QUERY  
oti=60000
```

Optionally these attributes can also be set when the client wants to fetch the message from the SC cache:

```
cid=CBCD_SECURITY_MARKET
```

SC receives the message and finds the server allocated to this session.

It sends the message SRV\_EXECUTE to the server it and awaits the response. Then it sends back a message with a body and the following attributes:

```
mty=CXE  
nam=P01_RTXS_RPRWS1  
sid=cdc50b36-1fc4-4f9e-8430-d2e3d7284d9d  
msn=974834  
min=SECURITY_MARKET_RESULT
```

Optionally these attributes can also be set when the server wants to store the message in the SC cache:

```
cid=CBCD_SECURITY_MARKET  
ced=1997-08-16T17:00:00.000+0100
```

In case of an application error these attributes can also be set.

```
aec=4334591  
aet=%RDB-F-NOTXT, no transaction open
```

In case the server does not respond within the given operation timeout (oti) the SC will abort the session, send CLN\_EXECUTE response an error back to the client and send the SRV\_ABORT\_SESSION to the server.

When an SC error occurs the response message contains the attributes:

```
mty=CXE  
sec=330  
set=Session does not exist
```

Large messages are supported in this context.

## 8.17 CSC\_EXECUTE (XXE)

This message is sent from the cascaded SC to another SC order to process the client execute request. The message has a body and contains these attributes:

```
mty=XXE  
nam=P01_RTXS_RPRWS1  
sid=cdc50b36-1fc4-4f9e-8430-d2e3d7284d9d  
msn=974833  
min=SECURITY_MARKET_QUERY
```

oti=60000

Optionally these attributes can also be set when the client wants to fetch the message from the SC cache:

cid=CBCD\_SECURITY\_MARKET

SC receives the message and process it like a CLN\_EXECUTE message. When an SC error occurs the response message contains the attributes:

mty=XXE  
sec=330  
set=Session does not exist

Large messages are supported in this context.

## 8.18 SRV\_EXECUTE (SXE)

This message is sent from the SC to the server allocated to this session in order to execute the request. The SC will send this message only in scope of a session. The message has a body and contains these attributes:

mty=SXE  
nam=P01\_RTXS\_RPRWS1  
sid=cdc50b36-1fc4-4f9e-8430-d2e3d7284d9d  
msn=974833  
min=SECURITY\_MARKET\_QUERY  
oti=18000

The server receives the message extracts the body and executes the application code. It must send back a message with a body and the following attributes:

mty=SXE  
nam=P01\_RTXS\_RPRWS1  
sid=cdc50b36-1fc4-4f9e-8430-d2e3d7284d9d  
msn=34834  
min=SECURITY\_MARKET\_RESULT

Optionally these attributes can also be set when the server wants to insert the message into the SC cache:

cid=CBCD\_SECURITY\_MARKET  
ced=1997-08-16T17:00:00.000+0100

In case of an application error these attributes can also be set.

aes=4334591  
aet=%RDB-F-NOTXT, no transaction open

## 8.19 ECHO (ECH)

This message is sent from the client to SC in order to verify the session consistency. The client must send this message in periodic intervals in scope of every session. In order to prevent session expiration in cascaded configurations while client is retrieving only data from a cache, ECHO can be sent even if an EXECUTE message is in progress. The message has no body and contains these attributes:

mty=ECH  
nam=P01\_RTXS\_RPRWS1  
sid=cdc50b36-1fc4-4f9e-8430-d2e3d7284d9d  
msn=974833  
oti=200

SC receives the message and verifies the allocated session. In cascaded configurations the message is forwarded to the SC holding the session. Then it sends back a message without body and the following attributes:

```
mty=ECH
nam=P01_RTXS_RPRWS1
sid=cdc50b36-1fc4-4f9e-8430-d2e3d7284d9d
msn=974834
```

When an SC error occurs the response message contains the attributes:

```
mty= ECH
sec=330
set=Session does not exist
```

## 8.20 CLN\_SUBSCRIBE (CSU)

This message is sent from the client to SC in order to subscribe for a publishing service. The message has optional a body and contains these attributes (as seen by the SC):

```
mty=CSU
msn=1
nam=P01_BCST_CH_RPRWS2
msk=000012100012832102FADF-----
ipl=10.0.4.32/10.0.4.32
sin=SNBZHP - TradingClientGUI 10.2.7
noi=300
oti=20000
```

SC receives the message and does these actions:

1. Generates a unique session id
2. Sends the message SRV\_SUBSCRIBE to the server registered for this service and awaits the server response.
3. If the server response message does not contain the attribute rejectFlag, the SC remembers the subscription mask of the client for this service and sends back to client the message with the following attributes:

```
mty=CSU
msn=1
nam=P01_BCST_CH_RPRWS2
sin=server-version:V2.1-453
sid=cdc50b36-1fc4-4f9e-8430-d2e3d7284d9d
```

4. If the server response message contains the attribute rejectFlag, the SC deletes the session, and sends back to client the message with the following attributes:

```
mty=CSU
msn=1
nam=P01_BCST_CH_RPRWS2
sin=server-version:V2.1-453
rej
aec=4334591
aet=%RTXS-E-NOPARTICIPANT, Authorization error - Unknown
participant
```

When an SC error occurs the response message contains the attributes:

```
mty=CSU
sec=400
set=Unkown service: P01_BCST_CH_RPRWS2
```

The subscription is synchronous operation. The client gets control when all SC components on the path to the publishing server are aware of the subscription. If SC cannot find server registered for this service it will respond with an error.

Large messages are not supported in this context.

## 8.21 CSC\_SUBSCRIBE (XSU)

This message is sent from the cascaded SC to another SC order to process the client subscription. The message has optional a body and contains these attributes:

```
mty=XSU
ver=1.0-023
msn=1
nam=P01_BCST_CH_RPRWS2
sid=cdc50b36-1fc4-4f9e-8430-d2e3d7284d9d
msk=000012100012832102FADF-----
cma=%%%%%%%%%%-----
ipl=10.0.4.32/10.0.4.32/10.2.54.12
sin=SNBZHP - TradingClientGUI 10.2.7
oti=10000
```

The SC receives the message, checks the version and processes it like a CLN\_SUBSCRIBE message. When an SC error occurs the response message contains the attributes:

```
mty=XSU
sec=400
set=Unkown service: P01_BCST_CH_RPRWS2
```

## 8.22 SRV\_SUBSCRIBE (SSU)

This message is sent from the SC to the server in order to process the client subscription (e.g. perform authentication). The message has optional a body and contains these attributes:

```
mty=SSU
msn=1
nam=P01_BCST_CH_RPRWS2
sid=cdc50b36-1fc4-4f9e-8430-d2e3d7284d9d
msk=000012100012832102FADF-----
ipl=10.0.4.32/10.0.4.32/10.2.54.12
sin=SNBZHP - TradingClientGUI 10.2.7
oti=10000
```

The server receives the message and must decide to accept or reject this request. If it accepts, then it must return a message with the following attributes:

```
mty=SSU
msn=1
nam=P01_BCST_CH_RPRWS2
sin=server-version:V2.1-453
sid=cdc50b36-1fc4-4f9e-8430-d2e3d7284d9d
```

If it rejects the session, then it must return a message with the following attributes:

```
mty=SSU
msn=1
nam=P01_BCST_CH_RPRWS2
sin=server-version:V2.1-453
sid=cdc50b36-1fc4-4f9e-8430-d2e3d7284d9d
rej
aec=4334591
aet=%RTXS-E-NOPARTICIPANT, Authorization error – Unknown participant
```

## 8.23 CLN\_CHANGE\_SUBSCRIPTION (CHS)

This message is sent from the client to SC in order to change the subscription for a publishing service. The message has optional a body and contains these attributes (as seen by the SC):

```
mty=CHS
msn=53834
```

```
nam=P01_BCST_CH_RPRWS2
sid=cdc50b36-1fc4-4f9e-8430-d2e3d7284d9d
msk=000012100012832102FADF-----
ipl=10.0.4.32/10.0.4.32
oti=10000
```

SC receives the message and does these actions:

1. Sends the message SRV\_CHANGE\_SUBSCRIPTION to the server registered for this service and awaits the server response.
2. If the server response message does not contain the attribute rejectFlag, the SC changes the subscription mask of the client for this service and sends back to client the message with the following attributes:  
mty=CHS  
msn=974834  
nam=P01\_BCST\_CH\_RPRWS2  
sid=cdc50b36-1fc4-4f9e-8430-d2e3d7284d9d
3. If the server response message contains the attribute rejectFlag, the SC keeps the previous subscription and sends back to client the message with the following attributes:  
mty=CHS  
msn=974834  
nam=P01\_BCST\_CH\_RPRWS2  
sid=cdc50b36-1fc4-4f9e-8430-d2e3d7284d9d  
rej  
aec=4334591  
aet=%RTXS-E-NOPARTICIPANT, Authorization error – Unknown participant

When an SC error occurs the response message contains the attributes:

```
mty=CHS
sec=320
set=Client is not subscribed
```

The change of the subscription is synchronous operation. The client gets control when all SC components on the path to the publishing server are aware of the new subscription. If SC cannot find server registered for this service it will respond with an error.

Large messages are not supported in this context.

## 8.24 CSC\_CHANGE\_SUBSCRIPTION (XHS)

This message is sent from cascaded SC to another SC in order to change the client subscription. The message has optional a body and contains these attributes:

```
mty=XHS
msn=53834
nam=P01_BCST_CH_RPRWS2
msk=000012100012832102FADF-----
cma=%%%%%%%%%%-----
ams=000012100012832102FADF-----
ipl=10.0.4.32/10.0.4.32/10.2.54.12
sid=cdc50b36-1fc4-4f9e-8430-d2e3d7284d9d
csi=6b0312d6-05eb-43ec-b74c-162e38d0e841
oti=10000
```

The SC receives the message and processes it like a CLN\_CHANGE\_SUBSCRIPTION message. When an SC error occurs the response message contains the attributes:

```
mty=XHS
sec=320
set=Client is not subscribed
```

## 8.25 SRV\_CHANGE\_SUBSCRIPTION (SHS)

This message is sent from SC to the server in order to change the client subscription. The message has optional a body and contains these attributes:

```
mty=SHS
msn=53834
nam=P01_BCST_CH_RPRWS2
ams=000012100012832102FADF-----
sid=cdc50b36-1fc4-4f9e-8430-d2e3d7284d9d
oti=10000
```

The server receives the message and must decide to accept or reject this request. If it accepts, then it must return a message with the following attributes:

```
mty=SHS
msn=1
nam=P01_BCST_CH_RPRWS2
sid=cdc50b36-1fc4-4f9e-8430-d2e3d7284d9d
```

If it rejects the session, then it must return a message with the following attributes:

```
mty=SHS
msn=1
nam=P01_BCST_CH_RPRWS2
sid=cdc50b36-1fc4-4f9e-8430-d2e3d7284d9d
rej
aec=4334591
aet=%RTXS-E-NOPARTICIPANT, Authorization error – Unknown participant
```

## 8.26 CLN\_UNSUBSCRIBE (CUN)

This message is sent from the client to SC in order to delete the subscription for a publishing service. The message has no body and contains these attributes:

```
mty=CUN
msn=53834
nam=P01_BCST_CH_RPRWS2
sid=cdc50b36-1fc4-4f9e-8430-d2e3d7284d9d
sin=rollback
oti=10000
```

SC receives the message and sends the message SRV\_UNSUBSCRIBE to the server registered for this service and awaits the server response. Then it sends back to client the message with the following attributes:

```
mty=CUN
msn=1
nam=P01_BCST_CH_RPRWS2
sid=cdc50b36-1fc4-4f9e-8430-d2e3d7284d9d
```

When an SC error occurs the response message contains the attributes:

```
mty=CUN
sec=230
set=Client is not subscribed
```

This operation is synchronous. The client gets control when all SC components on the path to the publishing server have deleted the subscription. If SC cannot find server registered for this service it will respond with an error.

## 8.27 CSC\_UNSUBSCRIBE (XUN)

This message is sent from cascaded SC to another SC in order to remove the client subscription (e.g. delete the session). The message has no body and contains these attributes:

```
mty=XUN
msn=53834
nam=P01_BCST_CH_RPRWS2
cma=%%%%%%%%%%-----
sid=cdc50b36-1fc4-4f9e-8430-d2e3d7284d9d
csi=6b0312d6-05eb-43ec-b74c-162e38d0e841
sin=rollback
oti=10000
```

The SC receives the message and processes it like a CLN\_UNSUBSCRIBE message. When an SC error occurs the response message contains the attributes:

```
mty=XUN
sec=320
set=Client is not subscribed
```

## 8.28 SRV\_UNSUBSCRIBE (SUN)

This message is sent from the SC to the server in order to remove the client subscription (e.g. delete the session). The message has no body and contains these attributes:

```
mty=SUN
msn=53834
nam=P01_BCST_CH_RPRWS2
sid=cdc50b36-1fc4-4f9e-8430-d2e3d7284d9d
sin=rollback
oti=10000
```

The server must return a message with the following attributes:

```
mty=SUN
msn=974834
nam=P01_BCST_CH_RPRWS2
sid=cdc50b36-1fc4-4f9e-8430-d2e3d7284d9d
```

## 8.29 CSC\_ABORT\_SUBSCRIPTION (XAB)

This message is sent by cascaded SC to another SC in order to terminate a subscription due to errors or other unexpected event. The message has no body and contains these attributes:

```
mty=XAB
nam=P01_RTXS_RPRWS1
sid=cdc50b36-1fc4-4f9e-8430-d2e3d7284d9d
csi=6b0312d6-05eb-43ec-b74c-162e38d0e841
sec=302
set=Session timeout exceeded
oti=2000
```

The SC holding the session transforms this message into a regular SRV\_ABORT\_SESSION message and sends it to the allocated server. Then it sends reply message to the cascaded SC with the following attributes:

```
mty=XAB
nam=P01_RTXS_RPRWS1
sid=cdc50b36-1fc4-4f9e-8430-d2e3d7284d9d
```

In case the server does not respond within the configured operation timeout (oti) the SC will abort the session, deregister the server and close all connections to the server.

### 8.30 SRV\_ABORT\_SUBSCRIPTION (SAB)

This message is sent from the SC to the server when the subscription is aborted due to errors or other unexpected event. The message has no body and contains these attributes:

```
mty=SAB
nam=P01_RTXS_RPRWS1
sid=cdc50b36-1fc4-4f9e-8430-d2e3d7284d9d
sec=302
set=Session timeout exceeded
oti=2000
```

The server must return a message with the following attributes:

```
mty=SAB
nam=P01_RTXS_RPRWS1
sid=cdc50b36-1fc4-4f9e-8430-d2e3d7284d9d
```

In case the server does not respond within the configured operation timeout (oti) the SC will abort the subscription, deregister the server and close all connections to the server.

### 8.31 RECEIVE\_PUBLICATION (CRP)

This message is sent from the client to SC in order to get data published by a server. The client may send this message only in scope of a subscription session. The message has no body and contains these attributes:

```
mty=CRP
sid=cdc50b36-1fc4-4f9e-8430-d2e3d7284d9d
nam=P01_BCST_CH_RPRWS2
msn=974833
```

SC receives the message and does these actions:

1. Finds the client subscription
2. Creates a timer monitoring the response delivery
3. Waits until one of these two events occurs:
  - a. A message that matches the client subscription arrives. Then it sends back a message with the body and the following attributes:

```
mty=CRP
sid=cdc50b36-1fc4-4f9e-8430-d2e3d7284d9d
nam=P01_BCST_CH_RPRWS2
msn=974834
min=CH_AUCTION
msk=%X%
```

- b. The *noDataInterval* (*noi*) timeout expires. Then it sends back a message with the no body and the following attributes:

```
mty=CRP
sid=cdc50b36-1fc4-4f9e-8430-d2e3d7284d9d
nam=P01_BCST_CH_RPRWS2
msn=974834
nod
```

When an SC error occurs the response message contains the attributes:

```
mty=CRP
sec=130
set=Client is not subscribed to service: P01_BCST_CH_RPRWS2
```



## 8.32 PUBLISH (SPU)

This message is sent from the publishing server to SC in order to send this message to the subscribed clients. The message has a body and contains these attributes:

```
mty=SPU
nam=P01_BCST_CH_RPRWS2
msn=65411
min=CH_AUCTION_IOI
msk=%X%
```

SC receives the message and does the following steps:

1. It inserts the message on top of the message queue for this service
2. Sends back to the server a message with the following attributes:

```
mty=SPU
nam=P01_BCST_CH_RPRWS2
msn=65412
```
3. Starts distribution of the message to the subscribed clients based on their subscription mask and the mask of the message.

When an SC error occurs the response message contains the attributes:

```
mty=SPU
sec=100
set=Service P01_BCST_CH_RPRWS2 does not exist
```

## 8.33 FILE\_DOWNLOAD (FDO)

This message is used to download file from a web server. The message has no body and contains these attributes:

```
mty=FDO
nam=P01_LOGGING
sid=cdc50b36-1fc4-4f9e-8430-d2e3d7284d9d
rfn=LSC TradingClientGUI_20100115_07h28m59s.log
oti=2000
```

The SC takes the message and initiates a download from the web server configured for this service. The requesting URL is constructed according to the configuration and the given remote file name. The response message has a body containing the file and has these attributes:

```
mty=FDO
bty=bin
nam=P01_LOGGING
sid=cdc50b36-1fc4-4f9e-8430-d2e3d7284d9d
rfn=LSC TradingClientGUI_20100115_07h28m59s.log
```

The maximal message length may exceed the 64kB limit.

On Error the SC may return message a response message contains the attributes:

```
mty=FDO
nam=P01_LOGGING
rfn=LSC TradingClientGUI_20100115_07h28m59s.log
sid=cdc50b36-1fc4-4f9e-8430-d2e3d7284d9d
sec=40
set=404 Not found
```

See <http://www.w3.org/Protocols/rfc2616/rfc2616-sec6.html#sec6.1.1> for possible status codes and reasons.

## 8.34 FILE\_UPLOAD (FUP)

This message is used to upload file to a web server. The message has a body containing the file and has these attributes:

```
mty=FUP
bty=bin
nam=P01_CONFIGURATION
sid=cdc50b36-1fc4-4f9e-8430-d2e3d7284d9d
rfn=SCconfig-P01-V3.3-433.properties
oti=2000
```

The SC takes the message and initiates an upload to the web server configured for this service. The requesting URL is constructed according to the configuration and the given remote file name. The response message has no body and has these attributes:

```
mty=FUP
nam=P01_LOGGING
sid=cdc50b36-1fc4-4f9e-8430-d2e3d7284d9d
rfn=SCconfig-P01-V3.3-433.properties
```

The maximal message length may exceed the 64kB limit. On Error the SC may return message a response message contains the attributes:

```
mty=FUP
nam=P01_LOGGING
sid=cdc50b36-1fc4-4f9e-8430-d2e3d7284d9d
rfn=SCconfig-P01-V3.3-433.properties
sec=40
set=406 Not Acceptable
```

See <http://www.w3.org/Protocols/rfc2616/rfc2616-sec6.html#sec6.1.1> for possible status codes and reasons.

## 8.35 FILE\_LIST (FLI)

This message is used to get list of files on web server. The Web Server must allow the directory browsing. The message has no body and these attributes:

```
mty=FLI
nam=P01_CONFIGURATION
sid=cdc50b36-1fc4-4f9e-8430-d2e3d7284d9d
oti=2000
```

The SC takes the message and creates an URL to explore the location on the web server corresponding to the service. The response message has body and has these attributes:

```
mty=FLI
bty=txt
nam=P01_CONFIGURATION
sid=cdc50b36-1fc4-4f9e-8430-d2e3d7284d9d
```

The response message body has the following format:

```
File name1<LF>
File name2<LF>
File name3<LF>
```

No header or footer is used. Each file name is on a separate line terminated by <CR><LF> Filenames appear as they are stored on disk. Upper / lowercase is depending on the operating system used. No file attributes like date or size is provided. The list order is not predictable. The physical location corresponding to the service is not disclosed.

The maximal message length may exceed the 64kB limit. On Error the SC may return message a response message contains the attributes:

```
mty=FLI  
nam=P01_CONFIGURATION  
sid=cdc50b36-1fc4-4f9e-8430-d2e3d7284d9d  
sec=40  
set=403 Forbidden
```

See <http://www.w3.org/Protocols/rfc2616/rfc2616-sec6.html#sec6.1.1> for possible status codes and reasons.

## 9 SCMP Header Attributes

The following is a list of all possible attributes in SC message header in alphabetical order. All attributes and their values are ASCII, encoded as ISO 8859-1 (Latin-1). “=” or <LF> are not allowed within attribute names and/or values. Unknown attributes will be ignored. Attribute values longer than the defined length will be truncated.

You can find the matrix describing which attribute is used in which message at the end of this document.

### 9.1 actualMask (ams)

|             |  |
|-------------|--|
| Name        | actualMask   |
| Code        | ams  |
| Description | The actual client subscription mask filled by SC in SRV_CHANGE_SUBSCRIPTION.               |
| Validation  | Any printable character, length $\leq$ 256Byte.  |
| Comment     | This mask is filled by SC and may be used by the server to check the subscription changes. |
| Example     | Subscription mask:<br>ams=000012100012832102FADF-----X-----                                |

### 9.2 appErrorCode (aec)

|             |  |
|-------------|--|
| Name        | appErrorCode   |
| Code        | aec  |
| Description | Numeric value passed between server and the client used to implement error protocol on the application level. Can be set by server whenever it responds with a message body. |
| Validation  | Numeric value $\geq$ 0,  |
| Comment     | This can be used by the client to check a specific server error. Value of -9999 is used internally in JavaAPI to signal empty code.  |
| Example     | aec=4334591  |

### 9.3 appErrorText (aet)

|             |  |
|-------------|--|
| Name        | appErrorText   |
| Code        | aet  |
| Description | Textual value passed between server and the client used to implement error protocol on the application level. It can be the textual interpretation of the <i>appErrorCode</i> . Can be set by server whenever it responds with a message body. |
| Validation  | Any printable character, length $>$ 0 and $\leq$ 256Byte   |
| Comment     | This can be used by the client to display or log an error that occurred on the server and so get the user better understanding what happened.  |
| Example     | aet=%RDB-F-NOTXT, no transaction open  |

### 9.4 bodyType (bty)

|             |   |
|-------------|---|
| Name        | bodyType  |
| Code        | bty   |
| Description | Type of the message body  |
| Validation  | Enumeration, 3 characters, fixed: <ul style="list-style-type: none"> <li>• txt – message body is ISO-8859-1 (Latin 1) encoded text</li> </ul> |

|         |   |
|---------|---|
|         | <ul style="list-style-type: none"> <li>bin – binary data</li> <li>xml – XML data (not implemented yet)</li> </ul> |
| Default | bin   |
| Comment | When http transport is used, the content-type header is set according to this attribute.                          |
| Example | bty=txt   |

## 9.5 cacheExpirationDateTime (ced)

|             |   |
|-------------|---|
| Name        | cacheExpirationDateTime   |
| Code        | ced   |
| Description | It is the absolute expiration date and time of the message in cache. It must be set by the server together with <i>cacheId</i> attribute. Server messages without <i>cacheExpirationDateTime</i> or without <i>cacheId</i> will not be cached.            |
| Validation  | YYYY-MM-DDThh:mm:ss.fff+hhmm<br>It is local date time plus zone information.<br>The fff are seconds fractions and time zone offset is at the end.   |
| Comment     | The server uses <i>cacheExpirationDateTime</i> to define how long the message is valid.<br><br>The client will get a cached message when the <i>cacheId</i> and <i>serviceName</i> matches a message in the cache and the cached message is timely valid. |
| Example     | ced=1997-08-16T19:20:34.237+0200  |

## 9.6 cacheId (cid)

|             |   |
|-------------|---|
| Name        | cacheId   |
| Code        | cid   |
| Description | Identification agreed by the communicating applications to uniquely identify the cached content. The <i>cacheId</i> is unique per service.  |
| Validation  | Any printable character except "/", length > 0 and ≤ 256Byte  |
| Comment     | The client uses <i>cacheId</i> to identify which message should be retrieved from the cache. The server uses <i>cacheId</i> to designate message that should be cached.<br><br>The client will get a cached message when the <i>cacheId</i> and <i>serviceName</i> matches a message in the cache and the cached message is timely valid. . |
| Example     | cid=CBCD_SECURITY_MARKET  |

## 9.7 cachePartNumber (cpn)

|             |   |
|-------------|---|
| Name        | cachePartNumber   |
| Code        | cpn   |
| Description | Sequence number generated by SC when large cached reply is passed to the client. It identifies the next reply part to be fetched from cache.                                |
| Validation  | Running number in format > 0, gaps are possible.  |
| Comment     | The client may receive this attribute when large reply is delivered from cache. The client passes the same <i>cachePartNumber</i> back to SC in order to get the next part. |
| Example     | cpn=123   |

## 9.8 cascadedMask (cma)

|             |   |
|-------------|---|
| Name        | cascadedMask  |
| Code        | cma   |
| Description | Subscription mask exchanged between cascaded SCs.         |
| Validation  | length ≥ 0 and ≤ 256Byte<br>It may contain "%" character. |

|         |  |
|---------|--|
| Comment | This attribute is sent by SC to another SC along the communication path. It contains the cumulative subscription mask of the SC. |
| Example | cascaded mask:<br><code>cma=0000121%#####-----X-----</code>  |

### 9.9 cascadedSubscriptionId (csi)

|             |  |
|-------------|--|
| Name        | cascadedSubscriptionId   |
| Code        | csi  |
| Description | Unique identification of the subscription of the SC (on-behalf client) in cascaded configurations.   |
| Validation  | Known subscription, length $\geq 0$ and $\leq 256$ Byte  |
| Comment     | This attribute is sent by SC to another SC along the communication path. It contains the subscription id of the SC performing the message fan-out. |
| Example     | <code>csi=cdc50b36-1fc4-4f9e-8430-d2e3d7284d9d</code>  |

### 9.10 compression (cmp)

|             |   |
|-------------|---|
| Name        | compression   |
| Code        | cmp   |
| Description | Flag true or false describing if the message body is compressed or not.   |
| Validation  | Present is true, missing is false   |
| Default     | true  |
| Comment     | The compression can be enabled or disabled on message level.<br>SC uses ZIP compression described in:<br><a href="http://www.pkware.com/documents/casestudies/APPNOTE.TXT">http://www.pkware.com/documents/casestudies/APPNOTE.TXT</a><br>and documented in:<br><a href="http://download.oracle.com/javase/1.4.2/docs/api/java/util/zip/Deflater.html">http://download.oracle.com/javase/1.4.2/docs/api/java/util/zip/Deflater.html</a> |
| Example     | cmp   |

### 9.11 checkRegistrationInterval (cri)

|             |   |
|-------------|---|
| Name        | checkRegistrationInterval   |
| Code        | cri   |
| Description | Interval in seconds between two subsequent CHECK_REGISTRATION messages sent by the server to SC. CHECK_REGISTRATION message may be sent even if an EXECUTE message is pending, but not when PUBLISH message is pending. On SC the <i>checkRegisrationInterval</i> is extended by <i>checkRegistrationIntervalMultiplier</i> (default = 1.2) in order to compensate network latency. |
| Validation  | Number $\geq 0$ and $\leq 3600$ Value = 0 means no monitoring of this interval in SC.   |
| Default     | 300   |
| Comment     | This is used by the SC to detect dead servers. The value should be set with respect to the throughput of the network connection. If this interval expires then the server is treated as dead and is deleted. Allocated sessions or subscriptions will be cleaned up.  |
| Example     | <code>cri=500</code>  |

### 9.12 echoInterval (eci)

|             |  |
|-------------|--|
| Name        | echoInterval   |
| Code        | eci  |
| Description | Interval in seconds between two subsequent ECHO messages sent by the client to SC. ECHO message may be sent even if an EXECUTE message is pending. On SC the <i>echoInterval</i> is extended by <i>echoIntervalMultiplier</i> (default = 1.2) in order to allow time for network transmission. When EXECUTE message is in progress, the <i>echoInterval</i> is extended by the <i>operationTimeout</i> in order to |

|            |  |
|------------|--|
|            | prevent expiration during long server processing.  |
| Validation | Number $\geq 10$ and $\leq 3600$   |
| Default    | 300  |
| Comment    | This is used by the SC to detect broken session. The value should be set with respect to the throughput of the network connection. If this interval expires then the session is treated as dead and is deleted. Allocated server will receive ABORT_SESSION message. |
| Example    | eci=300  |

### 9.13 immediateConnect (imc)

|             |  |
|-------------|--|
| Name        | immediateConnect   |
| Code        | imc  |
| Description | Flag true or false to tell SC when connection to the server should be created. It controls the creation of a static or dynamic connection pool   |
| Validation  | Present is true, missing is false.   |
| Default     | true   |
| Comment     | After server registers to a service, SC will create as many connections back to the server as defined by <i>maxSessions</i> . When <i>immediateConnect</i> = true, SC will create the connections immediately and keep them until Deregister_Server is done. When <i>immediateConnect</i> = false SC will create the connections on the fly, before they are needed and close them when they are idle for a long time or Deregister_Server is done |
| Example     | imc  |

### 9.14 ipAddressList (ipl)

|             |   |
|-------------|---|
| Name        | ipAddressList   |
| Code        | ipl   |
| Description | List of IP addresses on the network path between the client and the session server. The list contains IP addresses in the form 999.999.999.999:99999.   |
| Validation  | List in format {999.999.999.999/999.999.999.999}...   |
| Comment     | The list has at least three entries. <ol style="list-style-type: none"> <li>1. IP of the client,</li> <li>2. Incoming IP received by SC (IP of the VPN Tunnel)</li> <li>3. IP of the SC</li> </ol> <p>Client connected via cascaded SC placed in a customer DMZ will have the list in the format:</p> <ol style="list-style-type: none"> <li>1. IP of the client,</li> <li>2. Incoming IP received by SC in customer DMZ.</li> <li>3. IP of the SC in customer DMZ</li> <li>4. Incoming IP received by SC (IP of the VPN Tunnel)</li> <li>5. IP of the SC</li> </ol> <p>If any of the pairs at position 1-2 or 3-4 have different values, then NAT occurs in this network segment. As long as there is only one SC behind the VPN, the second last address is always the tunnel IP used for the authentication.</p> |
| Example     | ipl=10.0.4.32/10.0.4.32/10.2.54.12  |

### 9.15 keepaliveInterval (kpi)

|             |   |
|-------------|---|
| Name        | keepaliveInterval   |
| Code        | kpi   |
| Description | Interval in seconds between two subsequent keep-alive requests (KRQ). The keep-alive message is used to refresh the firewall timeout on the network path. SC monitors keep-alive messages from the server and performs server cleanup if the interval * <i>root.serverTimeoutMultiplier</i> property is exceeded. Keep-alive message is only sent on an idle connection. The value = 0 means no keep alive messages will be sent. |

|            |   |
|------------|---|
| Validation | Number $\geq 0$ and $\leq 3600$   |
| Default    | 60  |
| Comment    | The keepaliveInterval is exchanged at the beginning of the communication. In REGISTER_SERVER the <i>keepaliveInterval</i> defines how often the SC will sent keep-alive messages to the server. |
| Example    | kpi=360   |

## 9.16 localDateTime (ldt)

|             |  |
|-------------|--|
| Name        | localDateTime  |
| Code        | ldt  |
| Description | String value describing the actual local date and time.  |
| Validation  | YYYY-MM-DDThh:mm:ss.fff+hhmm<br>It is local date time plus zone information.<br>The fff are seconds fractions and time zone offset is at the end after the + sign.   |
| Comment     | The local date time is exchanged at the beginning of the communication (ATTACH, REGISTER_SERVER). It is used to calculate the time difference between the communicating parties and to harmonize the log for troubleshooting purposes. |
| Example     | ldt=1997-07-16T19:20:30.064+0100   |

## 9.17 messageInfo (min)

|             |   |
|-------------|---|
| Name        | messageInfo   |
| Code        | min   |
| Description | Optional information passed together with the message body that helps to identify the message content without investigating the body.   |
| Validation  | Any printable character, length $\geq 0$ and $\leq 256$ Byte  |
| Comment     | This can be set by the sender and evaluated by the receiver of the message to simplify decision how the message should be processed. It can also be used for troubleshooting to identify the message during the message transmission. |
| Example     | min=SECURITY_MARKET_QUERY   |

## 9.18 messageSequenceNumber (msn)

|             |   |
|-------------|---|
| Name        | messageSequenceNumber   |
| Code        | msn   |
| Description | Identification generated by the sender of a message in order to identify and track it during a session. The sessionId + the messageSequenceNumber <u>uniquely</u> identify the message. Numbering of request and response messages is independent. Error messages generated by SC never contain a messageSequenceNumber. ECHO message has no msn. |
| Validation  | Running number in format $> 0$ , the sequence is not validated by SC, gaps are possible. See also chapter 3.1.12 and 3.2.5  |
| Comment     | The message sequence number is reset at begin of the session and is steadily increasing, incremented by the sender. The messageSequenceNumber is also used to identify message parts in the cache.  |
| Example     | <pre> <b>REQ</b> .. <b>msn=3</b> <b>RES</b> .. <b>msn=64</b> ... <b>PRQ</b> .. <b>msn=4</b> PAC .. msn=65 PRQ .. msn=5 PAC .. msn=66 PRQ .. msn=6 PAC .. msn=67 <b>REQ</b> .. <b>msn=7</b> PRS .. msn=68 PAC .. msn=8 PRS .. msn=69 PAC .. msn=9           </pre>   |



|  |  |
|--|--|
|  | RES .. msn=70<br>...<br>REQ .. msn=10<br>RES .. msn=71 |
|--|--|

### 9.19 messageType (mty)

|             |  |
|-------------|--|
| Name        | messageType  |
| Code        | mty  |
| Description | Unique message type  |
| Validation  | 3 characters, fixed, uppercase, list of known message types  |
| Comment     | Message type that represents a certain command. The direction of the message is visible in the headline. |
| Example     | mty=ATT  |

### 9.20 mask (msk)

|             |  |
|-------------|--|
| Name        | mask   |
| Code        | msk  |
| Description | The mask is used in SUBSCRIBE or CHANGE_SUBSCRIPTION to express the client interest and in PUBLISH to designate the message contents. Only printable characters are allowed.   |
| Validation  | Any printable character, length $\leq 256$ Byte<br>Client may not subscribe with mask containing “%” character.  |
| Comment     | If the message mask matches the subscription mask, the client will get this message.<br>The matching rules: <ul style="list-style-type: none"> <li>• masks of unequal length <u>do not</u> match</li> <li>• % - matches any single character at this position</li> <li>• All other characters must exactly match (case sensitive)</li> </ul> |
| Example     | Subscription mask:<br>msk=000012100012832102FADF-----X-----<br><br>Matching examples of message masks:<br>msk=000012100012832102FADF-----X-----<br>msk=0000121%*****-----X-----<br><br><u>Not</u> matching examples of message masks:<br>msk=000012100012832102FADF-----<br>msk=0000121%*****-----X-----                                     |

### 9.21 maxConnections (mxc)

|             |  |
|-------------|--|
| Name        | maxConnections   |
| Code        | mxc  |
| Description | Number of connections (pool size) SC will create initially to communicate with the server.   |
| Validation  | Number $> 0$ and $\leq 1024$<br>If mxs = 1 then mxc = 1<br>If mxs $> 1$ then mxc $> 1$ and mxc $\leq$ mxs<br>(multi-session server with only 1 connection is not supported)  |
| Default     | mxs  |
| Comment     | When a server registers to a service it must tell the SC how many connections it can handle.<br>In case all connections are busy, SC will not start a new connection but keep trying to get a free connection until the <i>operationTimeout</i> defined in the message expires. Then it will return an error “no free connection available”. |

|         |        |
|---------|--------|
| Example | mxc=10 |
|---------|--------|

## 9.22 maxSessions (mxc)

|             |   |
|-------------|---|
| Name        | maxSessions   |
| Code        | mxc   |
| Description | Number of sessions this server instance can serve.  |
| Validation  | Number > 0  |
| Comment     | When a server registers to a service it must tell the SC how many sessions it can serve. This is necessary to know in order to maintain the count of free/busy servers in SC.<br>The value 1 means single session server. Value > 1 means multi-session server. See also <i>immediateConnect</i> flag.<br>In case all servers are busy, SC will keep trying to get a free server until the <i>operationTimeout</i> defined in the message expires. Then it will return an error "no free server available". |
| Example     | mxc=10  |

## 9.23 noData (nod)

|             |   |
|-------------|---|
| Name        | noData  |
| Code        | nod   |
| Description | NoData flag is used in RECEIVE_PUBLICATION to tell the subscribed client, that no data for publishing exists. The client must immediately send another RECEIVE_PUBLICATION to renew the interest. |
| Validation  | Present is true, missing is false.  |
| Comment     | No msn is sent when this flag is set  |
| Example     | nod   |

## 9.24 noDataInterval (noi)

|             |  |
|-------------|--|
| Name        | noDataInterval   |
| Code        | noi  |
| Description | Interval in seconds the SC will wait to deliver RECEIVE_PUBLICATION response with <i>noData</i> flag set.    |
| Validation  | Number $\geq 10$ and $\leq 3600$   |
| Default     | 300  |
| Comment     | The receiving client monitors the interval and treats the subscription as broken when this time is exceeded. |
| Example     | noi=60   |

## 9.25 operationTimeout (oti)

|             |  |
|-------------|--|
| Name        | operationTimeout   |
| Code        | oti  |
| Description | Maximal expected operation duration time in milliseconds defined by the client. The client should set a realistic value according to the expected operation executed by the service.   |
| Validation  | Number $\geq 1000$ and $\leq 3600000$  |
| Default     | 60000  |
| Comment     | This is used by to make all operations non-blocking. When this timeout expires, client will get an error message with OPERATION_TIMEOUT_EXPIRED error code. In order to compensate the network traffic latency, SC uses a configurable multiplier (default = 0.8) to monitor the timeout. This may cause an expiration before the expected time. Under heavy load the given timeout may also be exceeded. Delivery of the error message is guaranteed. |
| Example     | oti=10000  |

## 9.26 portNr (pnr)

|             |  |
|-------------|--|
| Name        | portNr   |
| Code        | pnr  |
| Description | Number of the TCP/IP port the session server accepts the connection(s).  |
| Validation  | Number > 1 and ≤ 65534   |
| Comment     | When a session server registers to a service, SC will create a connection to this server on the IP address of the server and the given port number. Multiple connections are created to the same port. |
| Example     | pnr=9100   |

## 9.27 rejectSession (rej)

|             |  |
|-------------|--|
| Name        | rejectSession  |
| Code        | rej  |
| Description | Flag in SRV_CREATE_SESSION, SRV_SUBSCRIBE, SRV_CHANGE_SUBSCRIPTION response message set by the server when it rejects the session. |
| Validation  | Present is true, missing is false.   |
| Default     | false  |
| Comment     | The server should also set the <i>appErrorCode</i> and <i>appErrorText</i> to explain the rejection reason.                        |
| Example     | rej  |

## 9.28 remoteFileName (rfn)

|             |   |
|-------------|---|
| Name        | remoteFileName  |
| Code        | rfn   |
| Description | Name used in FILE_UPLOAD to store the file on the web server or name used in FILE_DOWNLOAD to identify the file to be downloaded. |
| Validation  | Any printable character allowed as filename, length ≤ 256Byte   |
| Comment     |   |
| Example     | rfn=LSC TradingClientGUI_20100115_07h28m59s.log   |

## 9.29 scErrorCode (sec)

|             |   |
|-------------|---|
| Name        | scErrorCode   |
| Code        | sec   |
| Description | Numeric error code set by SC in other to inform the communication partner about an error. List of possible error codes will be published. |
| Validation  | Number > 0 and < 1000   |
| Comment     | This is used to handle the SC error. The message must have EXC key in the headline.   |
| Example     | sec=453   |

## 9.30 scErrorText (set)

|             |   |
|-------------|---|
| Name        | scErrorText   |
| Code        | set   |
| Description | English text set by the SC in other to describe the error signalled as <i>scErrorCode</i> . Precise error description must be here. |
| Validation  | Any printable character, length > 0 and ≤ 256Byte   |
| Comment     | This is used to log or display the SC error. The message must have EXC key in the headline.   |
| Example     | set=Unknow service name: P01_RTXR_RPRWS4  |

### 9.31 scVersion (ver)

|             |   |
|-------------|---|
| Name        | scVersion   |
| Code        | ver   |
| Description | Software version number of the producer of this message.  |
| Validation  | String format 9.9-999   |
| Comment     | <p>This version number is sent in ATTACH, REGISTER_SERVER, SCS_CREATE_SESSION or SCS_SUBSCRIB and checked by the receiver against its own SC version number. This ensures that only compatible components can communicate to each other. The value is hard coded in the communication components like API or SC. The version number looks like 3.2-023:</p> <ul style="list-style-type: none"> <li>• 3 = Release number</li> <li>• 2 = Version number</li> <li>• 023 = Revision number</li> </ul> <p>The matching rules are:</p> <ul style="list-style-type: none"> <li>• Request: 3.2-023 + own: 3.2-023 =&gt; compatible</li> <li>• Request: 3.2-021 + own: 3.2-023 =&gt; compatible</li> <li>• Request: 3.1-006 + own: 3.2-023 =&gt; compatible</li> <li>• Request: 3.2-025 + own: 3.2-023 =&gt; <u>not</u> compatible (requestor may utilize new features unknown here)</li> <li>• Request: 3.3-005 + own: 3.2-023 =&gt; <u>not</u> compatible (requestor uses new functions unknown here)</li> <li>• Request: 2.2-023 + own: 3.2-023 =&gt; <u>not</u> compatible (possibly other incompatible interface)</li> <li>• Request: 4.0-007 + own: 3.2-023 =&gt; <u>not</u> compatible (possibly other incompatible interface)</li> </ul> |
| Example     | ver=3.2-023   |

### 9.32 serviceName (nam)

|             |  |
|-------------|--|
| Name        | serviceName  |
| Code        | nam  |
| Description | Name of the service  |
| Validation  | Any printable character, length > 0 and ≤ 32Byte.  |
| Comment     | The service name is an abstract name and represents the logical address of the service. In order to allow message routing the name must be unique in scope of the entire SC network. Service names must be agreed at the application level and are stored in the SC configuration. |
| Example     | nam=P01_RTXS_RPRWS1  |

### 9.33 sessionId (sid)

|             |   |
|-------------|---|
| Name        | sessionId   |
| Code        | sid   |
| Description | Unique identification of the session  |
| Validation  | Known session, length ≥ 0 and ≤ 256Byte   |
| Comment     | <p>The sessionId is allocated by SC to which the client is connected when it sends the request CLN_CREATE_SESSION. The sessionId is universally unique because multiple SC may exist in the same network. The client must set the sessionId in each message during the session.</p> <p>For publishing services the sessionId is allocated by SC to the client when it sends the request SUBSCRIBE message. Subscription is internally treated as a session.</p> |
| Example     | sid=cdc50b36-1fc4-4f9e-8430-d2e3d7284d9d  |

### 9.34 sessionInfo (sin)

|             |  |
|-------------|--|
| Name        | sessionInfo  |
| Code        | sin  |
| Description | Optional information passed by the client to the session server when the session starts. |
| Validation  | Any printable character, length $\geq 0$ and $\leq 256$ Byte                             |
| Comment     | This is used to pass additional authentication or authorization data to the server.      |
| Example     | sin=SNBZHP - TradingClientGUI 10.2.7   |

### 9.35 urlPath (urp)

|             |  |
|-------------|--|
| Name        | urlPath  |
| Code        | urp  |
| Description | Optional attribute sent in REGISTER_SERVER by servers residing in Tomcat in order to identify the web application instance.  |
| Validation  | Any printable character, length $\geq 0$ and $\leq 256$ Byte   |
| Comment     | This string is used in web.xml as <url-pattern> in section <filter-mapping> to define dispatching of incoming http request to the web-application that implements the service. |
| Example     | urp=/scmp/t02/dcm-service/   |

### 9.36 appendixNumber (anr)

|             |  |
|-------------|--|
| Name        | appendixNumber   |
| Code        | anr  |
| Description | Header attribute indicates what position current appendix in context of the whole message takes in. This supports the process of reading appendices between clients and proxies. |
| Validation  | Running number in format $> 0$ .   |
| Comment     | This number is used for execute requests to read appendices cached on a proxy.   |
| Example     | anr=3  |

### 9.37 numberOfAppendix (nra)

|             |  |
|-------------|--|
| Name        | numberOfAppendix   |
| Code        | nra  |
| Description | Header attribute indicates how many appendices belonging to the parent message exist. This supports the process of loading appendices between clients and proxies. |
| Validation  | Running number in format $> 0$ .   |
| Comment     | This number is used for execute requests to load appendices cached on a proxy.   |
| Example     | nra=3  |

### 9.38 cachingMethod (cmt)

|             |   |
|-------------|---|
| Name        | cachingMethod   |
| Code        | cmt   |
| Description | Attribute sent in Publish or Response of Session request. More details in 3.1.3 in SC_CC_V1.1.pdf.        |
| Validation  | Possible values for cmt: initial, remove, append, empty string. Empty string causes data to be unmanaged. |
| Comment     | Attribute needed by the cache module to evaluate how to manage received data.                             |
| Example     | cmt=initial   |

# 10

# Glossary

|                     |  |
|---------------------|--|
| <b>Client</b>       | Piece of an application consuming services and initiating actions.   |
| <b>Server</b>       | Piece of an application providing services to clients.   |
| <b>Service</b>      | Abstract unit of work provided by the server and delivered to the client in order to implement a specific functionality. SC supports session, publishing and file services.                          |
| <b>Session</b>      | Temporary allocation of a dedicated server to a client. Session ensures information flow between a client and the allocated server. SC supports request/response sessions and subscription sessions. |
| <b>Call</b>         | A call represents a pair of a request and response.  |
| <b>Command</b>      | A command dispatches specific actions on a server according to the incoming request.   |
| <b>Request</b>      | Data structure created by the Client or SC in order to initiate an information exchange. It may contain one or more messages.  |
| <b>Response</b>     | Data structure created by the Server or SC in order to deliver the requested information. It may contain one or more messages.   |
| <b>Message</b>      | Basic transport instrument to exchange information between client, SC and the server. It belongs to a request or to a response.  |
| <b>Message Part</b> | Message part is a piece of a large message. Large message is broken into parts.  |
| <b>Composite</b>    | Data structure prepared to hold all message parts of a large message   |
| <b>Registry</b>     | Common list of known objects that ensures their uniqueness, organized in a way to find them easily.  |
| <b>Requester</b>    | Piece of code in SC or client initiating the information exchange  |
| <b>Responder</b>    | Piece of code in SC or server delivering the requested information   |
| <b>Connection</b>   | Network communication between client and SC or SC and the server   |
| <b>Endpoint</b>     |  |

Network communication part on SC or server

## Appendix A - Message Header Matrix

|                    |     | actualMask (ams) | appErrorCode (aec) | appErrorText(aet) | bodyType (bty) | cacheId (cid) | cachePartNumber (cpn) | cacheExpirationDate Time (ced) | cascadedMask (cma) | cascadedSubscriptionId(csi) | compression (cmp) | checkRegistrationInterval (cri) | echoInterval (eci) | immediateConnect (ime) | ipAddressList (ipl) | keepAliveInterval (kpi) | localDate Time (ldt) | messageInfo (min) | messageSequenceNumber (msn) | messageType (mty) | mask (msk) | maxConnections (mxc) | maxSessions (mxs) | noData (nod) | noDataInterval (noi) | operationTimeout (oti) | portNr (pnr) | rejectSession (rej) | remoteFileName (rfn) | scError Code (sec) | scErrorText (set) | scVersion (ver) | serviceName (nam) | sessionId (sid) | sessionInfo (sin) | urPath (urp) | appendixNumber (anr) | numberOfAppendix (nr) | cachingMethod (cmt) |  |  |  |  |  |  |  |
|--------------------|-----|------------------|--------------------|-------------------|----------------|---------------|-----------------------|--------------------------------|--------------------|-----------------------------|-------------------|---------------------------------|--------------------|------------------------|---------------------|-------------------------|----------------------|-------------------|-----------------------------|-------------------|------------|----------------------|-------------------|--------------|----------------------|------------------------|--------------|---------------------|----------------------|--------------------|-------------------|-----------------|-------------------|-----------------|-------------------|--------------|----------------------|-----------------------|---------------------|--|--|--|--|--|--|--|
| ATTACH             | REQ |                  |                    |                   |                |               |                       |                                |                    |                             |                   |                                 |                    |                        |                     | X                       |                      |                   | X                           |                   |            |                      |                   |              |                      |                        |              |                     |                      |                    |                   |                 |                   |                 |                   |              |                      |                       |                     |  |  |  |  |  |  |  |
|                    | RES |                  |                    |                   |                |               |                       |                                |                    |                             |                   |                                 |                    |                        |                     | X                       |                      |                   | X                           |                   |            |                      |                   |              |                      |                        |              |                     | E                    | E                  |                   |                 |                   |                 |                   |              |                      |                       |                     |  |  |  |  |  |  |  |
| DETACH             | REQ |                  |                    |                   |                |               |                       |                                |                    |                             |                   |                                 |                    |                        |                     |                         |                      |                   | X                           |                   |            |                      |                   |              |                      |                        |              |                     |                      |                    |                   |                 |                   |                 |                   |              |                      |                       |                     |  |  |  |  |  |  |  |
|                    | RES |                  |                    |                   |                |               |                       |                                |                    |                             |                   |                                 |                    |                        |                     |                         |                      |                   | X                           |                   |            |                      |                   |              |                      |                        |              |                     | E                    | E                  |                   |                 |                   |                 |                   |              |                      |                       |                     |  |  |  |  |  |  |  |
| INSPECT            | REQ |                  |                    |                   | X              |               |                       |                                |                    |                             | O                 |                                 |                    |                        | X                   |                         |                      |                   | X                           |                   |            |                      |                   |              |                      |                        |              |                     |                      |                    |                   |                 |                   |                 |                   |              |                      |                       |                     |  |  |  |  |  |  |  |
|                    | RES |                  |                    |                   | X              |               |                       |                                |                    |                             | O                 |                                 |                    |                        | X                   |                         |                      |                   | X                           |                   |            |                      |                   |              |                      |                        |              |                     | E                    | E                  |                   |                 |                   |                 |                   |              |                      |                       |                     |  |  |  |  |  |  |  |
| MANAGE             | REQ |                  |                    |                   | X              |               |                       |                                |                    |                             | O                 |                                 |                    |                        | X                   |                         |                      |                   | X                           |                   |            |                      |                   |              |                      |                        |              |                     |                      |                    |                   |                 |                   |                 |                   |              |                      |                       |                     |  |  |  |  |  |  |  |
|                    | RES |                  |                    |                   | X              |               |                       |                                |                    |                             | O                 |                                 |                    |                        | X                   |                         |                      |                   | X                           |                   |            |                      |                   |              |                      |                        |              |                     | E                    | E                  |                   |                 |                   |                 |                   |              |                      |                       |                     |  |  |  |  |  |  |  |
| CLN_CREATE_SESSION | REQ |                  |                    |                   | O              |               |                       |                                |                    |                             | O                 | X                               |                    |                        | X                   |                         |                      | X                 | X                           |                   |            |                      |                   | X            |                      |                        |              |                     |                      |                    |                   |                 |                   | X               |                   | O            |                      |                       |                     |  |  |  |  |  |  |  |
|                    | RES | O                | O                  | O                 | O              |               |                       |                                |                    |                             | O                 |                                 |                    |                        |                     |                         |                      | X                 | X                           |                   |            |                      |                   |              |                      |                        | O            | E                   | E                    |                    |                   | X               | X                 |                 | X                 | O            |                      |                       |                     |  |  |  |  |  |  |  |
| CSC_CREATE_SESSION | REQ |                  |                    |                   | O              |               |                       |                                |                    |                             | O                 | X                               |                    |                        | X                   |                         |                      | X                 | X                           |                   |            |                      |                   | X            |                      |                        |              |                     |                      |                    |                   | X               |                   |                 | X                 | O            |                      |                       |                     |  |  |  |  |  |  |  |
|                    | RES | O                | O                  | O                 | O              |               |                       |                                |                    |                             | O                 |                                 |                    |                        |                     |                         |                      | X                 | X                           |                   |            |                      |                   |              |                      |                        |              | O                   | E                    | E                  |                   |                 | X                 | X               |                   | X            | O                    |                       |                     |  |  |  |  |  |  |  |
| SRV_CREATE_SESSION | REQ |                  |                    |                   | O              |               |                       |                                |                    |                             | O                 |                                 |                    |                        | X                   |                         |                      | X                 | X                           |                   |            |                      |                   | X            |                      |                        |              |                     |                      |                    |                   |                 | X                 | X               |                   | X            | O                    |                       |                     |  |  |  |  |  |  |  |
|                    | RES | O                | O                  | O                 | O              |               |                       |                                |                    |                             | O                 |                                 |                    |                        |                     |                         |                      | X                 | X                           |                   |            |                      |                   |              |                      |                        |              | O                   |                      |                    |                   |                 | X                 | X               |                   | X            | O                    |                       |                     |  |  |  |  |  |  |  |
| CLN_DELETE_SESSION | REQ |                  |                    |                   |                |               |                       |                                |                    |                             |                   |                                 |                    |                        |                     |                         |                      | X                 | X                           |                   |            |                      |                   | X            |                      |                        |              |                     |                      |                    |                   |                 | X                 | X               |                   | X            | O                    |                       |                     |  |  |  |  |  |  |  |
|                    | RES |                  |                    |                   |                |               |                       |                                |                    |                             |                   |                                 |                    |                        |                     |                         |                      | X                 | X                           |                   |            |                      |                   |              |                      |                        |              |                     | E                    | E                  |                   |                 | X                 | X               |                   | X            | O                    |                       |                     |  |  |  |  |  |  |  |
| CSC_DELETE_SESSION | REQ |                  |                    |                   |                |               |                       |                                |                    |                             |                   |                                 |                    |                        |                     |                         |                      | X                 | X                           |                   |            |                      |                   | X            |                      |                        |              |                     |                      |                    |                   |                 | X                 | X               |                   | X            | O                    |                       |                     |  |  |  |  |  |  |  |
|                    | RES |                  |                    |                   |                |               |                       |                                |                    |                             |                   |                                 |                    |                        |                     |                         |                      | X                 | X                           |                   |            |                      |                   |              |                      |                        |              |                     | E                    | E                  |                   |                 | X                 | X               |                   | X            | O                    |                       |                     |  |  |  |  |  |  |  |
| SRV_DELETE_SESSION | REQ |                  |                    |                   |                |               |                       |                                |                    |                             |                   |                                 |                    |                        |                     |                         |                      | X                 | X                           |                   |            |                      |                   | X            |                      |                        |              |                     |                      |                    |                   |                 | X                 | X               |                   | X            | O                    |                       |                     |  |  |  |  |  |  |  |
|                    | RES |                  |                    |                   |                |               |                       |                                |                    |                             |                   |                                 |                    |                        |                     |                         |                      | X                 | X                           |                   |            |                      |                   |              |                      |                        |              |                     |                      |                    |                   |                 | X                 | X               |                   | X            | O                    |                       |                     |  |  |  |  |  |  |  |
| SRV_ABORT_SESSION  | REQ |                  |                    |                   |                |               |                       |                                |                    |                             |                   |                                 |                    |                        |                     |                         |                      | X                 | X                           |                   |            |                      |                   | X            |                      |                        |              |                     | X                    | X                  |                   |                 | X                 | X               |                   | X            |                      |                       |                     |  |  |  |  |  |  |  |
|                    | RES |                  |                    |                   |                |               |                       |                                |                    |                             |                   |                                 |                    |                        |                     |                         |                      | X                 | X                           |                   |            |                      |                   |              |                      |                        |              |                     |                      |                    |                   |                 | X                 | X               |                   | X            |                      |                       |                     |  |  |  |  |  |  |  |
| REGISTER_SERVER    | REQ |                  |                    |                   |                |               |                       |                                |                    |                             | X                 | O                               |                    | X                      | X                   |                         |                      | X                 |                             | X                 | X          |                      |                   |              |                      | X                      |              |                     |                      |                    |                   | X               | X                 |                 |                   |              |                      | O                     |                     |  |  |  |  |  |  |  |
|                    | RES |                  |                    |                   |                |               |                       |                                |                    |                             |                   |                                 |                    |                        |                     |                         | X                    |                   | X                           |                   |            |                      |                   |              |                      |                        |              |                     | E                    | E                  |                   |                 | X                 |                 |                   |              |                      |                       |                     |  |  |  |  |  |  |  |
| CHECK_REGISTRATION | REQ |                  |                    |                   |                |               |                       |                                |                    |                             |                   |                                 |                    |                        |                     |                         |                      | X                 |                             | X                 |            |                      |                   |              |                      |                        |              |                     |                      |                    |                   |                 | X                 |                 |                   |              |                      |                       |                     |  |  |  |  |  |  |  |



|                         |         | actualMask (ams) | appErrorCode (aec) | appErrorText(aet) | bodyType (bty) | cacheId (cid) | cachePartNumber (cpn) | cacheExpirationDate Time (ced) | cascadedMask (cma) | cascadedSubscriptionId(csi) | compression (cmp) | checkRegistrationInterval (cri) | echoInterval (eci) | immediateConnect (ime) | ipAddressList (ipl) | keepAliveInterval (kpi) | localDate Time (ldt) | messageInfo (min) | messageSequenceNumber (msn) | messageType (mty) | mask (msk) | maxConnections (maxc) | maxSessions (maxs) | noData (nod) | noDataInterval (noi) | operationTimeout (oti) | portNr (pnr) | rejectSession (rej) | remoteFileName (rfn) | scErrorCode (sec) | scErrorText (set) | scVersion (ver) | serviceName (nam) | sessionId (sid) | sessionInfo (sin) | urlPath (urp) | appendixNumber (anr) | numberOfAppendix (nr) | cachingMethod (cnt) |  |  |   |
|-------------------------|---------|------------------|--------------------|-------------------|----------------|---------------|-----------------------|--------------------------------|--------------------|-----------------------------|-------------------|---------------------------------|--------------------|------------------------|---------------------|-------------------------|----------------------|-------------------|-----------------------------|-------------------|------------|-----------------------|--------------------|--------------|----------------------|------------------------|--------------|---------------------|----------------------|-------------------|-------------------|-----------------|-------------------|-----------------|-------------------|---------------|----------------------|-----------------------|---------------------|--|--|---|
|                         | RES     |                  |                    |                   |                |               |                       |                                |                    |                             |                   |                                 |                    |                        |                     |                         |                      |                   | X                           |                   |            |                       |                    |              |                      |                        |              |                     |                      |                   |                   |                 |                   |                 |                   |               |                      |                       |                     |  |  |   |
| DEREGISTER_SERVER       | REQ     |                  |                    |                   |                |               |                       |                                |                    |                             |                   |                                 |                    |                        |                     |                         |                      |                   | X                           |                   |            |                       |                    |              |                      |                        |              |                     |                      |                   |                   |                 |                   |                 |                   |               |                      |                       |                     |  |  |   |
|                         | RES     |                  |                    |                   |                |               |                       |                                |                    |                             |                   |                                 |                    |                        |                     |                         |                      |                   | X                           |                   |            |                       |                    |              |                      |                        |              |                     |                      |                   |                   |                 |                   |                 |                   |               |                      |                       |                     |  |  |   |
| CLN_EXECUTE             | REQ/PRQ |                  |                    |                   | O              | O             |                       |                                |                    |                             | O                 |                                 |                    |                        |                     |                         | O                    | X                 | X                           |                   |            |                       |                    |              | X                    |                        |              |                     |                      |                   |                   |                 |                   |                 |                   |               |                      |                       | O                   |  |  |   |
|                         | RES/PRS | O                | O                  | O                 | O              | O             | O                     | O                              |                    |                             | O                 |                                 |                    |                        |                     |                         | O                    | X                 | X                           |                   |            |                       |                    |              |                      |                        |              |                     |                      |                   |                   |                 |                   |                 |                   |               |                      |                       |                     |  |  |   |
|                         | PAC     |                  |                    |                   |                | O             | O                     |                                |                    |                             |                   |                                 |                    |                        |                     |                         |                      | X                 | X                           |                   |            |                       |                    |              | X                    |                        |              |                     |                      |                   |                   |                 |                   |                 |                   |               |                      |                       |                     |  |  |   |
| CSC_EXECUTE             | REQ/PRQ |                  |                    |                   | O              | O             |                       |                                |                    |                             | O                 |                                 |                    |                        |                     |                         | O                    | X                 | X                           |                   |            |                       |                    |              | X                    |                        |              |                     |                      |                   |                   |                 |                   |                 |                   |               |                      |                       |                     |  |  |   |
|                         | RES/PRS | O                | O                  | O                 | O              | O             | O                     | O                              |                    |                             | O                 |                                 |                    |                        |                     |                         | O                    | X                 | X                           |                   |            |                       |                    |              |                      |                        |              |                     |                      |                   |                   |                 |                   |                 |                   |               |                      |                       |                     |  |  |   |
|                         | PAC     |                  |                    |                   |                | O             | O                     |                                |                    |                             |                   |                                 |                    |                        |                     |                         |                      | X                 | X                           |                   |            |                       |                    |              | X                    |                        |              |                     |                      |                   |                   |                 |                   |                 |                   |               |                      |                       |                     |  |  |   |
| SRV_EXECUTE             | REQ/PRQ |                  |                    |                   | O              | O             |                       |                                |                    |                             | O                 |                                 |                    |                        |                     |                         | O                    | X                 | X                           |                   |            |                       |                    |              | X                    |                        |              |                     |                      |                   |                   |                 |                   |                 |                   |               |                      |                       |                     |  |  |   |
|                         | RES/PRS | O                | O                  | O                 | O              |               |                       | O                              |                    |                             | O                 |                                 |                    |                        |                     |                         | O                    | X                 | X                           |                   |            |                       |                    |              |                      |                        |              |                     |                      |                   |                   |                 |                   |                 |                   |               |                      |                       |                     |  |  | O |
|                         | PAC     |                  |                    |                   |                |               |                       |                                |                    |                             |                   |                                 |                    |                        |                     |                         |                      | X                 | X                           |                   |            |                       |                    |              | X                    |                        |              |                     |                      |                   |                   |                 |                   |                 |                   |               |                      |                       |                     |  |  |   |
| ECHO                    | REQ     |                  |                    |                   |                |               |                       |                                |                    |                             |                   |                                 |                    |                        |                     |                         |                      |                   | X                           |                   |            |                       |                    |              | X                    |                        |              |                     |                      |                   |                   |                 |                   |                 |                   |               |                      |                       |                     |  |  |   |
|                         | RES     |                  |                    |                   |                |               |                       |                                |                    |                             |                   |                                 |                    |                        |                     |                         |                      |                   | X                           |                   |            |                       |                    |              |                      |                        |              |                     |                      |                   |                   |                 |                   |                 |                   |               |                      |                       |                     |  |  |   |
| FILE_DOWNLOAD           | REQ     |                  |                    |                   |                |               |                       |                                |                    |                             |                   |                                 |                    |                        |                     |                         |                      |                   | X                           |                   |            |                       |                    |              | X                    |                        |              |                     |                      |                   |                   |                 |                   |                 |                   |               |                      |                       |                     |  |  |   |
|                         | RES/PRS |                  |                    |                   |                |               |                       |                                |                    |                             |                   |                                 |                    |                        |                     |                         |                      |                   | X                           |                   |            |                       |                    |              |                      |                        |              |                     |                      |                   |                   |                 |                   |                 |                   |               |                      |                       |                     |  |  |   |
|                         | PAC     |                  |                    |                   |                |               |                       |                                |                    |                             |                   |                                 |                    |                        |                     |                         |                      | X                 | X                           |                   |            |                       |                    |              | X                    |                        |              |                     |                      |                   |                   |                 |                   |                 |                   |               |                      |                       |                     |  |  |   |
| FILE_UPLOAD             | REQ/PRQ |                  |                    |                   |                |               |                       |                                |                    |                             |                   |                                 |                    |                        |                     |                         |                      |                   | X                           |                   |            |                       |                    |              | X                    |                        |              |                     |                      |                   |                   |                 |                   |                 |                   |               |                      |                       |                     |  |  |   |
|                         | RES/PRS |                  |                    |                   |                |               |                       |                                |                    |                             |                   |                                 |                    |                        |                     |                         |                      |                   | X                           |                   |            |                       |                    |              |                      |                        |              |                     |                      |                   |                   |                 |                   |                 |                   |               |                      |                       |                     |  |  |   |
|                         | PAC     |                  |                    |                   |                |               |                       |                                |                    |                             |                   |                                 |                    |                        |                     |                         |                      | X                 | X                           |                   |            |                       |                    |              | X                    |                        |              |                     |                      |                   |                   |                 |                   |                 |                   |               |                      |                       |                     |  |  |   |
| FILE_LIST               | REQ     |                  |                    |                   |                |               |                       |                                |                    |                             |                   |                                 |                    |                        |                     |                         |                      |                   | X                           |                   |            |                       |                    |              | X                    |                        |              |                     |                      |                   |                   |                 |                   |                 |                   |               |                      |                       |                     |  |  |   |
|                         | RES     |                  |                    |                   |                |               |                       |                                |                    |                             | O                 |                                 |                    |                        |                     |                         |                      |                   | X                           |                   |            |                       |                    |              |                      |                        |              |                     |                      |                   |                   |                 |                   |                 |                   |               |                      |                       |                     |  |  |   |
| CLN_SUBSCRIBE           | REQ     |                  |                    |                   | O              |               |                       |                                |                    |                             | O                 |                                 |                    |                        | X                   |                         |                      | X                 | X                           | X                 |            |                       |                    | X            | X                    |                        |              |                     |                      |                   |                   |                 |                   |                 |                   |               |                      |                       |                     |  |  |   |
|                         | RES     | O                | O                  | O                 |                |               |                       |                                |                    |                             | O                 |                                 |                    |                        |                     |                         |                      | X                 | X                           |                   |            |                       |                    |              |                      |                        |              |                     |                      |                   |                   |                 |                   |                 |                   |               |                      |                       |                     |  |  |   |
| CSC_SUBSCRIBE           | REQ     |                  |                    |                   |                |               |                       | X                              | X                  | O                           |                   |                                 |                    |                        | X                   |                         |                      | X                 | X                           | X                 |            |                       |                    | X            | X                    |                        |              |                     |                      |                   |                   |                 |                   |                 |                   |               |                      |                       |                     |  |  |   |
|                         | RES     | O                | O                  | O                 |                |               |                       |                                |                    |                             | O                 |                                 |                    |                        |                     |                         |                      | X                 | X                           |                   |            |                       |                    |              |                      |                        |              |                     |                      |                   |                   |                 |                   |                 |                   |               |                      |                       |                     |  |  |   |
| SRV_SUBSCRIBE           | REQ     |                  |                    |                   | O              |               |                       |                                |                    |                             | O                 |                                 |                    |                        | X                   |                         |                      | X                 | X                           | X                 |            |                       |                    |              | X                    |                        |              |                     |                      |                   |                   |                 |                   |                 |                   |               |                      |                       |                     |  |  |   |
|                         | RES     | O                | O                  | O                 |                |               |                       |                                |                    |                             | O                 |                                 |                    |                        |                     |                         |                      | X                 | X                           |                   |            |                       |                    |              |                      |                        |              |                     |                      |                   |                   |                 |                   |                 |                   |               |                      |                       |                     |  |  |   |
| CLN_CHANGE_SUBSCRIPTION | REQ     |                  |                    |                   | O              |               |                       |                                |                    |                             | O                 |                                 |                    |                        | X                   |                         |                      | X                 | X                           | X                 |            |                       |                    |              | X                    |                        |              |                     |                      |                   |                   |                 |                   |                 |                   |               |                      |                       |                     |  |  |   |
|                         | RES     | O                | O                  | O                 |                |               |                       |                                |                    |                             | O                 |                                 |                    |                        |                     |                         |                      | X                 | X                           |                   |            |                       |                    |              |                      |                        |              |                     |                      |                   |                   |                 |                   |                 |                   |               |                      |                       |                     |  |  |   |
| CSC_CHANGE_SUBSCRIPTION | REQ     | X                |                    |                   | O              |               |                       | X                              | X                  | O                           |                   |                                 |                    |                        | X                   |                         |                      | X                 | X                           | X                 |            |                       |                    |              | X                    |                        |              |                     |                      |                   |                   |                 |                   |                 |                   |               |                      |                       |                     |  |  |   |
|                         | RES     | O                | O                  | O                 |                |               |                       |                                |                    |                             | O                 |                                 |                    |                        |                     |                         |                      | X                 | X                           |                   |            |                       |                    |              |                      |                        |              |                     |                      |                   |                   |                 |                   |                 |                   |               |                      |                       |                     |  |  |   |

|                         |         | actualMask (ams) | appErrorCode (aec) | appErrorText(aet) | bodyType (bty) | cacheId (cid) | cachePartNumber (cpn) | cacheExpirationDate Time (ced) | cascadedMask (cma) | cascadedSubscriptionId(csi) | compression (cmp) | checkRegistrationInterval (cri) | echoInterval (eci) | immediateConnect (ime) | ipAddressList (ipl) | keepAliveInterval (kpi) | localDate Time (ldt) | messageInfo (min) | messageSequenceNumber (msn) | messageType (mty) | mask (msk) | maxConnections (maxc) | maxSessions (maxs) | noData (nod) | noDataInterval (noi) | operationTimeout (oti) | portNr (pnr) | rejectSession (rej) | remoteFileName (rfn) | scErrorCode (sec) | scErrorText (set) | scVersion (ver) | serviceName (nam) | sessionId (sid) | sessionInfo (sin) | urIPath (urp) | appendixNumber (anr) | numberOfAppendix (nr) | cachingMethod (cnt) |  |  |  |   |   |
|-------------------------|---------|------------------|--------------------|-------------------|----------------|---------------|-----------------------|--------------------------------|--------------------|-----------------------------|-------------------|---------------------------------|--------------------|------------------------|---------------------|-------------------------|----------------------|-------------------|-----------------------------|-------------------|------------|-----------------------|--------------------|--------------|----------------------|------------------------|--------------|---------------------|----------------------|-------------------|-------------------|-----------------|-------------------|-----------------|-------------------|---------------|----------------------|-----------------------|---------------------|--|--|--|---|---|
| SRV_CHANGE_SUBSCRIPTION | REQ     | X                |                    |                   |                |               |                       |                                |                    |                             | O                 |                                 |                    |                        | X                   |                         |                      | X                 | X                           | X                 |            |                       |                    |              | X                    |                        |              |                     |                      |                   |                   |                 |                   |                 |                   |               |                      |                       |                     |  |  |  |   |   |
|                         | RES     |                  | O                  | O                 | O              |               |                       |                                |                    |                             |                   |                                 |                    |                        |                     |                         |                      | X                 | X                           |                   |            |                       |                    |              |                      |                        | O            |                     |                      |                   |                   |                 | X                 | X               | O                 |               |                      |                       |                     |  |  |  |   |   |
| CLN_UNSUBSCRIBE         | REQ     |                  |                    |                   |                |               |                       |                                |                    |                             |                   |                                 |                    |                        |                     |                         |                      | X                 | X                           |                   |            |                       |                    |              | X                    |                        |              |                     |                      |                   |                   |                 |                   |                 |                   |               |                      |                       |                     |  |  |  |   |   |
|                         | RES     |                  |                    |                   |                |               |                       |                                |                    |                             |                   |                                 |                    |                        |                     |                         |                      | X                 | X                           |                   |            |                       |                    |              |                      |                        |              |                     | E                    | E                 |                   |                 | X                 | X               |                   |               |                      |                       |                     |  |  |  |   |   |
| CSC_UNSUBSCRIBE         | REQ     |                  |                    |                   |                |               |                       | O                              | X                  |                             |                   |                                 |                    |                        |                     |                         |                      | X                 | X                           | O                 |            |                       |                    |              | X                    |                        |              |                     |                      |                   |                   |                 |                   |                 |                   |               |                      |                       |                     |  |  |  |   |   |
|                         | RES     |                  |                    |                   |                |               |                       |                                |                    |                             |                   |                                 |                    |                        |                     |                         |                      | X                 | X                           |                   |            |                       |                    |              |                      |                        |              |                     | E                    | E                 |                   |                 | X                 | O               | O                 |               |                      |                       |                     |  |  |  |   |   |
| SRV_UNSUBSCRIBE         | REQ     |                  |                    |                   |                |               |                       |                                |                    |                             |                   |                                 |                    |                        |                     |                         |                      | X                 | X                           |                   |            |                       |                    |              | X                    |                        |              |                     |                      |                   |                   |                 |                   |                 |                   |               |                      |                       |                     |  |  |  |   |   |
|                         | RES     |                  |                    |                   |                |               |                       |                                |                    |                             |                   |                                 |                    |                        |                     |                         |                      | X                 | X                           |                   |            |                       |                    |              |                      |                        |              |                     |                      |                   |                   |                 |                   |                 |                   |               |                      |                       |                     |  |  |  |   |   |
| CSC_ABORT_SUBSCRIPTION  | REQ     |                  |                    |                   |                |               |                       | O                              | X                  |                             |                   |                                 |                    |                        |                     |                         |                      | X                 | X                           |                   |            |                       |                    |              | X                    |                        |              |                     |                      | X                 | X                 |                 |                   |                 |                   |               |                      |                       |                     |  |  |  |   |   |
|                         | RES     |                  |                    |                   |                |               |                       |                                | X                  |                             |                   |                                 |                    |                        |                     |                         |                      | X                 | X                           |                   |            |                       |                    |              |                      |                        |              |                     |                      |                   |                   |                 |                   |                 |                   |               |                      |                       |                     |  |  |  |   |   |
| SRV_ABORT_SUBSCRIPTION  | REQ     |                  |                    |                   |                |               |                       |                                |                    |                             |                   |                                 |                    |                        |                     |                         |                      | X                 | X                           |                   |            |                       |                    |              | X                    |                        |              |                     |                      |                   |                   |                 |                   |                 |                   |               |                      |                       |                     |  |  |  |   |   |
|                         | RES     |                  |                    |                   |                |               |                       |                                |                    |                             |                   |                                 |                    |                        |                     |                         |                      | X                 | X                           |                   |            |                       |                    |              |                      |                        |              |                     |                      |                   |                   |                 |                   |                 |                   |               |                      |                       |                     |  |  |  |   |   |
| RECEIVE_PUBLICATION     | REQ/PAC |                  |                    |                   |                |               |                       |                                |                    |                             |                   |                                 |                    |                        |                     |                         |                      | X                 | X                           |                   |            |                       |                    |              |                      |                        |              |                     |                      |                   |                   |                 |                   |                 |                   |               |                      |                       |                     |  |  |  |   |   |
|                         | RES/PRS |                  |                    |                   | O              |               |                       |                                |                    |                             | O                 |                                 |                    |                        |                     |                         | O                    | X                 | X                           | I                 |            |                       | O                  |              |                      |                        |              |                     |                      | E                 | E                 |                 |                   | X               | X                 |               |                      |                       |                     |  |  |  | O |   |
| PUBLISH                 | REQ/PRQ |                  |                    |                   | O              | O             |                       |                                |                    |                             | O                 |                                 |                    |                        |                     |                         |                      | X                 | X                           | X                 |            |                       |                    |              |                      |                        |              |                     |                      |                   |                   |                 |                   |                 |                   |               |                      |                       |                     |  |  |  |   | O |
|                         | RES     |                  |                    |                   |                |               |                       |                                |                    |                             |                   |                                 |                    |                        |                     |                         |                      | X                 | X                           |                   |            |                       |                    |              |                      |                        |              |                     |                      | E                 | E                 |                 |                   | X               |                   |               |                      |                       |                     |  |  |  |   |   |
|                         | PAC     |                  |                    |                   |                |               |                       |                                |                    |                             |                   |                                 |                    |                        |                     |                         |                      | X                 |                             |                   |            |                       |                    |              |                      |                        |              |                     |                      |                   |                   |                 |                   |                 |                   |               |                      |                       |                     |  |  |  |   |   |

Legend:

X => required attribute  
O => optional attribute  
I => informational only  
E => EXC exception message only

Headline Keys:

REQ => request  
RES => response  
PRQ => part request (large message)  
PRS => part response (large message)  
PAC => part acknowledge (large message)  
KRQ => keep-alive request  
KRS => keep-alive response  
EXC => exception

## Appendix B – SC Error Codes and Messages

| Code | Internal Mnemonic                    | Text   |
|------|--------------------------------------|--|
| 400  | BAD_REQUEST                          | Bad request. The incoming request could not be understood due to malformed syntax. |
| 401  | SERVICE_NOT_FOUND                    | Service not found.   |
| 402  | SESSION_NOT_FOUND                    | Session not found.   |
| 403  | SUBSCRIPTION_NOT_FOUND               | Subscription not found.  |
| 404  | SERVER_NOT_FOUND                     | Server not found.  |
| 405  | REQUEST_TIMEOUT                      | Request Timeout. The SC did not timely respond to the request.                     |
| 406  | REQUEST_WAIT_ABORT                   | Emergency abort of the request.  |
| 407  | BROKEN_SESSION                       | Session is broken.   |
| 408  | BROKEN_SUBSCRIPTION                  | Subscription is broken.  |
|      |                                      |  |
| 420  | HV_ERROR                             | Validation error.  |
| 421  | HV_WRONG_SC_VERSION_FORMAT           | Invalid SC version format.   |
| 422  | HV_WRONG_SC_RELEASE_NR               | Incompatible SC release nr.  |
| 423  | HV_WRONGSC_VERSION_NR                | Incompatible SC version nr.  |
| 424  | HV_WRONG_SC_REVISION_NR              | Incompatible sc revision nr.   |
| 425  | HV_WRONG_SCMF_VERSION_FORMAT         | Invalid SCMP version format.   |
| 426  | HV_WRONG_SCMF_RELEASE_NR             | Incompatible SCMP release nr.  |
| 427  | HV_WRONG_SCMF_VERSION_NR             | Incompatible SCMP version nr.  |
| 428  | HV_WRONG_LDT                         | Invalid localDateTime format.  |
| 429  | HV_WRONG_CED                         | Invalid cacheExpirationDateTime format.  |
| 430  | HV_WRONG_IPLIST                      | Invalid iplist value.  |
| 431  | HV_WRONG_MAX_SESSIONS                | Invalid maxSessions value.   |
| 432  | HV_WRONG_MAX_CONNECTIONS             | Invalid maxConnections value.  |
| 433  | HV_WRON_OPERATION_TIMEOUT            | Invalid operationTimeout value.  |
| 434  | HV_WRONG_ECHO_TIMEOUT                | Invalid echoTimeout value.   |
| 435  | HV_WRONG_ECHO_INTERVAL               | Invalid echoInterval value.  |
| 436  | HV_WRONG_PORTNR                      | Invalid portNr.  |
| 437  | HV_WRONG_KEEPALIVE_INTERVAL          | Invalid keepaliveInterval value.   |
| 438  | HV_WRONG_KEEPALIVE_TIMEOUT           | Invalid keepaliveTimeout value.  |
| 439  | HV_WRONG_NODATA_INTERVAL             | Invalid notDataInterval value.   |
| 440  | HV_WRONG_MASK                        | Invalid mask.  |
| 441  | HV_WRONG_SESSION_INFO                | Invalid sessionInfo value.   |
| 442  | HV_WRONG_SERVICE_NAME                | Invalid serviceName value.   |
| 443  | HV_WRONG_MESSAGE_INFO                | Invalid messageInfo value.   |
| 444  | HV_WRONG_MESSAGE_SEQUENCE_NR         | Invalid messageSequenceNumber.   |
| 445  | HV_WRONG_REMOTE_FILE_NAME            | Invalid remoteFileName value.  |
| 446  | HV_WRONG_SESSION_ID                  | Invalid sessionId value.   |
| 447  | HV_WRONG_SC_ERROR_CODE               | Invalid scErrorCode value.   |
| 448  | HV_WRONG_SC_ERROR_TEXT               | Invalid scErrorText value.   |
| 449  | HV_WRONG_APP_ERROR_CODE              | Invalid appErrorCode value.  |
| 450  | HV_WRONG_APP_ERROR_TEXT              | Invalid appErrorText value.  |
| 451  | HV_WRONG_RECEIVE_PUBLICATION_TIMEOUT | Invalid receivePublicationTimeout value.   |
| 452  | HV_WRONG_CHECK_REGISTRATION_INTERVAL | Invalid checkRegistrationInterval value.   |
| 453  | HV_WRONG_CACHING_METHOD_VALUE        | Invalid cachingMethod value.   |
|      |                                      |  |
| 460  | V_WRONG_CONFIGURATION_FILE           | Invalid configuration file.  |
| 461  | V_WRONG_INSPECT_COMMAND              | Invalid inspect command.   |
| 462  | V_WRONG_MANAGE_COMMAND               | Invalid manage command.  |
| 463  | V_WRONG_SERVICE_TYPE                 | Invalid service type.  |
| 464  | V_WRONG_SERVER_TYPE                  | Invalid server type.   |
|      |                                      |  |
| 500  | SERVER_ERROR                         | Server error.  |
| 501  | SERVICE_DISABLED                     | Service is disabled  |
| 504  | OPERATION_TIMEOUT_EXPIRED            | The server did not timely respond to the request.                                  |
| 505  | UPLOAD_FILE                          | Upload file failed.  |
|      |                                      |  |
| 600  | SC_ERROR                             | Service Connector error.   |
| 601  | NO_SERVER                            | No server.   |
| 602  | NO_FREE_SERVER                       | No free server available.  |
| 603  | NO_FREE_CONNECTION                   | No free connection to server available.  |
| 604  | SERVER_ALREADY_REGISTERED            | Server is already registered for the service.                                      |
| 605  | FRAME_DECODER                        | Unable to decode message, SCMP headline is wrong.                                  |
| 606  | SESSION_ABORT                        | Session aborted.   |
| 607  | CONNECTION_EXCEPTION                 | Connection error.  |
| 608  | CACHE_ERROR                          | Cache error.   |
| 609  | CACHE_LOADING                        | Cache loading. Retry later.  |
| 610  | CACHE_MANAGER_ERROR                  | Cache Manager error  |
| 611  | PARALLEL_REQUEST                     | Parallel client request rejected   |

# Index

**No index entries found.**